

PROTECTING USONIA
A HOMEOWNER'S AND SITE MANAGER'S RESOURCE FOR UNDERSTANDING AND ADDRESSING
COMMON PRESERVATION CONCERNS IN FRANK LLOYD WRIGHT'S USONIAN HOME

A THESIS

SUBMITTED ON THE 29TH DAY OF APRIL 2018
TO THE DEPARTMENT OF PRESERVATION STUDIES
IN PARTIAL FULFILLMENT OF THE REQUIREMENTS OF
THE SCHOOL OF ARCHITECTURE
OF TULANE UNIVERSITY
FOR THE DEGREE
OF
MASTER OF PRESERVATION STUDIES

BY
EMILY BUTLER

APPROVED: _____
Professor John Stubbs
Director

Table of Contents

Chapter 1 Introduction.....	3
Personal Statement.....	3
Primary Goals.....	6
Methodology.....	7
Chapter 2 Understanding Wright.....	9
Historical Background.....	9
Organic Architecture As Described By Wright.....	13
Usonia: Concept to Reality.....	16
Usonian Forms: Module and Unit System.....	25
Common Building Materials and Elements.....	30
A Note on Sustainability.....	32
Chapter 3 Case Studies in Preserving Usonian Homes.....	33
Case Study: Herbert Jacobs House.....	33
Case Study: Kentuck Knob – I.N. & Bernardine Hagan House.....	40
Case Study: Rosenbaum House.....	57
Case Study: Pope-Leighey House.....	66
Chapter 4 Homeowners and Public Sites Survey.....	71
Survey Results.....	74
An Analysis of the Results.....	87
Failure of In-Floor Radiant Heating Systems.....	88
Leaking Roofs.....	101
Failure of Exterior Roof Finish/Wood Degradation.....	116
Cracked or Damaged Concrete Floors.....	126
Mortar Deterioration.....	132
Retro-fitting: Glass.....	137
Extraneous Concerns.....	140
Deflecting/ Sagging Cantilever.....	140
Textile/Concrete Block Deterioration.....	142
Resources for Locating Specialized Contractors and Materials.....	148
Conclusions.....	149

Chapter 1 Introduction

Personal Statement

This thesis topic was inspired by my intimate experience with a facet of Frank Lloyd Wright's architecture; a Usonian home commonly referred to as Kentuck Knob but known more formally as the I.N. and Bernardine Hagan house. When I left college, I became employed at this house, which is run as a publicly toured house museum. I had had no previous experience working with a mid-century style of home, much less a Frank Lloyd Wright design. As such, I was thrown into a situation where I had to learn very quickly the intricacies of the house. While Kentuck Knob is in good shape it was far from idyllic – needing wood refinished, repointing of the front steps, and a repair of a leaky kitchen roof.

As I was now the person who would be addressing these issues I had to learn quickly to develop a preservation plan for the home. This baptism by fire was the true inspiration for my thesis topic, which attempts to identify and propose solutions for common preservation problems that occur in Frank Lloyd Wright Usonian homes. Once these issues are identified this thesis will attempt to give potential solutions by providing case study preservation projects, suggesting materials or resources, and discussing proper methodology and preservation practice for addressing the most common issues.

The first step in understanding the issues present in these homes is to understand Frank Lloyd Wright, his design, and his philosophy on architecture. This is done in this thesis by a brief

analysis of his personal and professional life. Wright's history plays a major role in how he developed his Usonian concept.

The second step is to clearly define Wright's Usonian designs and how they reflect Wright's personal beliefs and design philosophies. This section will outline the history behind the development of the Usonian concept including historical context, its architectural characteristics, and will discuss variations within those characteristics.

With this important background information in hand, the paper then moves to discuss case study Usonian houses that have either undergone extensive restoration projects, have been re-sited, or are quintessential examples of successful preservation projects. The case study houses include the Rosenbaum House in Florence, Alabama; Kentuck Knob in Chalk Hill, PA; Jacobs I in Madison, Wisconsin, and the Pope-Leighey house currently located at the Woodlawn property in Virginia. These are not the only houses studied within this paper but serve to provide as examples that can be applied to other homes.

Common preservation or conservation problems were researched and analyzed as a part of the scope of this work. The most common issues are addressed here in detail, describing the typical nature of the failure, identifying first steps in addressing these issues, and giving resources and examples of successful methodologies and materials.

It is the end goal of this thesis that all these combined elements will create a resource for understanding and addressing these common concerns for homeowners and site managers of Wright's Usonian designs, which exist all across the United States.

The large majority of the data and first-hand knowledge comes from homes owned privately. It is the fact that most of these homes are in private hands, lived in everyday, or cared for on a regular basis by a community, trust, or other private or non-profit organization that so many remain with us and that so many will be preserved for future generations of inhabitants. It with this belief in the importance of the homeowners and organizations as major forces in preservation that this thesis is being written as a guide to help these stewards in preserving a piece of architectural history.

Primary Goals

The primary goal of this thesis is to provide owners and stewards of Usonian homes with as many possible resources to make informed maintenance and conservation decisions, believing that in giving these resources to those most involved with the process these extant Usonian homes will be preserved to the highest degree of integrity. It was vital that most of the information come from homeowner's themselves, as they have the most current, in-depth and practical knowledge about common preservation concerns in the Usonian style of home. As a part of this goal first hand knowledge from the Usonian homeowners were collected, analyzed, and synthesized to develop a usable resource based on their experiences and additional research and recommendation from professionals in the field.

The secondary goal of this project is to contribute to the current database of the Frank Lloyd Wright Building Conservancy on Usonian homes. The results of the survey will be included in the database and will contribute to their mission. The Frank Lloyd Wright Building Conservancy works to provide in-depth resources for homeowner's as well as serves as one of the premier advocates for the preservation of Wright's extant buildings. As such, they offer extensive practical preservation resources for all Wright homeowners. This paper, and the data collected from the survey, will serve to increase their knowledge base and, therefore, their ability to provide more in-depth resources to all homeowners, stewards, and scholars.

Methodology

The methodology in developing this thesis can be largely broken down into three main sections through which most of the information in this work is sourced. These three sections work together to make-up the resources needed to create a thorough, valid, and useful resource.

The initial step in the research process was to develop a comprehensive bibliography on the subject of Frank Lloyd Wright's life and work, his Usonian concepts and designs, and the preservation of his buildings, Usonian or otherwise. As Wright is one of the most celebrated architects in the United States, there is plethora of literature on these subjects. After this compilation process, it was then prudent to sift through what was useful for this project. This literature review provided valuable background information on Wright's life and the Usonian homes. Additionally, this literature also provided information on several of the case study houses, their history, and restoration projects. Later in the research process, the literature review was expanded to include technical information on the building systems and materials in the common preservation concerns section and the suggestions therein.

As this thesis focuses on both past and current preservation issues within these homes, it was important to gather information from the current or recent-past owners of some of these Usonian homes. This information was gathered in two primary ways. The first of which was in person or phone interviews with owners or stewards, discussing their experiences preserving their home or the issues they felt were most prevalent. This methodology was initially implemented with the case study homes; however, it was necessary to cast a wider net.

A Usonian Homeowner's Survey was developed with the assistance of the Frank Lloyd Wright Building Conservancy and distributed to their database of Usonian homeowners. Working with the Frank Lloyd Wright Building Conservancy was an invaluable resource as their goals and mission are in line with the goals of this thesis. This survey served to capture more qualitative, as well as quantitative, data on the most common preservation concerns or issues among Usonian homes. The complete survey can be viewed in the appendix of this work. The combination of these methodologies has gathered the needed information for a thorough analysis necessary for this paper and has been effective in making conclusions about issues and their solutions.

Chapter 2

Understanding Wright: Historical Background

A Look at Frank Lloyd Wright's Life & Career

Early Years

Frank Lloyd Wright was born to William Carey Wright and Anna Lloyd Jones in Richland Center, Wisconsin in 1867. His father, a preacher and musician, was often on the road and Wright spent most of his time with his mother. Anna Lloyd Jones', Wright's mother, came from a large family who held strong beliefs in the Unitarian religion and followed the philosophies of thinkers and authors such as Thoreau and Emerson.¹

Anna had believed, when she was carrying Wright, that he was destined to become an architect and gave him Froebel blocks to play with as a young boy, which eventually would be influential in his career. Froebel's simple geometry would stay with Wright through his entire career, stating that he could feel the blocks in his hands towards the end of his life.

A love of nature is also something that Wright learned at an early age. Wright spent summers on his uncle's farm in Wisconsin, learned the value of hard work, and learned to respect and revere the land. Wright would eventually emulate this physical connection to the land with the Fellowship at Taliesin and Taliesin West.

¹ Ian Volner and Michael Kirkham, *This is Frank Lloyd Wright* (London: Laurence King Publishing, 2016), 7.

Chicago and the Prairie Style

Wright left Wisconsin and traveled to Chicago, where he was eventually employed at the architectural firm of Adler and Sullivan. Louis Sullivan was a powerhouse figure in Chicago at this time and is famed for coining the phrase “form follows function”.² Sullivan was a revolutionary who was pushing forward the concept of the skyscraper and was rejecting the Beaux Arts style of architecture, which was exemplified by the Chicago World’s Fair. Wright learned much at his time under Louis Sullivan, a man he respected, referring to him as Leiber Meister.³

During this time Wright also met and wed his first wife, Katherine, Kitty, Lee Tobin. Kitty was from an upper-class family, which inevitably helped Wright gain connections for his Oak Park design years. Once he left Adler & Sullivan’s firm, he went out on his own. Toward the end of the 19th century and at beginning of the 20th, Wright achieves success with his Prairie style homes.

Early examples of this style include the Ward Willits House and the William Winslow House, characterized by deep overhanging eaves, bands of windows, low hipped roofs, and beautiful leaded art glass designs. These homes are low, mimicking the prairie landscape from which the inspiration came.

Wright is primarily considered a residential architect, however, some of his most impressive designs are his commercial ones. In this “Prairie” era of Wright’s career he began to

² Ian Volner and Michael Kirkham, *This is Frank Lloyd Wright* (London: Laurence King Publishing, 2016), 12.

³ *Ibid.*

branch out into this realm, starting with the Larkin Administration Building (1904-1906). This era in Wright's life was immensely important and set him up as a highly paid and sought-after architect.⁴

Taliesin

Wright eventually moved back to his home state of Wisconsin and built Taliesin – a house that represented his heritage in name and represented its place by material. Taliesin means “Shining Brow” and is the name of the protagonist in Welsh folklore. The building materials for the home came from the site – from the exterior limestone to the interior plaster. The home also included some elements of Japanese influences.⁵

During this time Wright acquired one of his most important commissions, The Imperial Hotel in Tokyo, Japan. From here Wright began moving further West and developed his ideas of the textile block home construction in California. The most famous examples of these include the Ennis House and Hollyhock House, both in Los Angeles.

The Fellowship, an apprenticeship program, was developed during this period as well. An all-encompassing apprenticeship, the fellows would live and work on the site. Their work did not only include assisting with Wright's architectural commissions, but labor on the farm, building, and helping with domestic chores.

⁴ Ian Volner and Michael Kirkham, *This is Frank Lloyd Wright* (London: Laurence King Publishing, 2016), 37.

⁵ Ibid.

Organic Architecture, Usonia, & Fallingwater

In the first part of the 20th century Wright developed further his ideas of Organic Architecture, which centered around his thoughts on how a house should relate to its inhabitants and its landscape. Organic architecture, for Wright, was not a mimicking of nature, but rather its reflection in daily life and into his architecture.

During this time, Wright was developing his ideas about Usonia and the houses that bear that name. This will be discussed in some detail in further sections of this work. Wright also gained, arguably, the most iconic commission of his career, Fallingwater. This home, as well as the Johnson Wax Headquarters, helped to bring Wright back into the spotlight.

Wright designed and built Taliesin West, in Arizona, where he and the Fellows would spend their winters. They spent many years traveling between the Taliesins, with the apprentices becoming key tools for Wright, as he sent them to supervise his smaller residential projects.

Toward the end of Wright's career and life he was extraordinarily popular and saw great commissions such as the Guggenheim Museum and the Beth Shalom Synagogue. Wright passed away in 1959, but his legacy lives on through his architecture and a way of living that is ever so important today.⁶

⁶ Ian Volner and Michael Kirkham, *This is Frank Lloyd Wright* (London: Laurence King Publishing, 2016), 63,77.

Organic Architecture as Described by Wright

Wright's organic architecture was at the forefront of his plans for Broadacre City, the Usonian home and community, and his general philosophy on how Americans, or Usonians, should live. This section features select quotes from Wright that exemplify his thoughts on organic architecture, which go far beyond a home connected to the landscape.

"I felt sure, even then, that architecture which was really architecture proceeded from the ground and that somehow the terrain, the native industrial conditions, the nature of the materials and the purpose of the building, must inevitably determine the form and character of any good building."⁷

Wright's concepts behind what he refers to as organic architecture are becoming fully formed during this period and have as much to do with society as it does with individual buildings. Wright believed in a decentralized plan and a new democracy that is very much in line with his Broadacre city concept, in which the Usonian home lies. Wright's organic ideals brought people closer to the land, away from cities, and in a more cooperative union.

Wright believed that an organic state was dynamic and not static. Organicism is something that is ever evolving, a biological system working together as a part of a whole.

"An Organic Architecture means more or less organic society. Organic ideals of integral building rejects rules imposed by exterior aestheticism or mere taste, and so would the people to who such architecture would belong reject such external impositions upon life as were not in

⁷ Frank Lloyd Wright and Andrew Saint, *An Organic Architecture the Architecture of Democracy* (London: Lund Humphries, 2017), 19.

accord with the nature and character of the man who had found his work and the place where he could be happy and useful because of it in some scheme of livelihood fair to him” – Frank Lloyd Wright London, May 20, 1939.⁸

Wright’s organic architecture rejected the classical styles of architecture that were popular at the time and that mimicked their European predecessors. Wright thought of the Japanese style of architecture to be more in line with his organic ideals. Japanese influence is clear in much of Wright’s designs. These feelings were also rooted in Wright’s rejection of European modernism and his desire to create a truly American, or Usonian, style of building and way of living.

“Now let me reiterate – the word “organic” does not, cannot apply to so-called classic architecture in any form whatsoever, and it does not apply to any of the “period” buildings, even the ‘Georgian’ in which we live today. The term does not apply to anything else we happen to have. It would apply, however, to the old Japanese buildings; Japanese domestic architecture was truly organic architecture. It would apply to certain other periods in the architectures of the world. Egyptian architecture was in a sense organic architecture, an expression of the feeling for human form. The Gothic cathedrals in the Middle Ages had much in them that was organic in character, and they became influential and beautiful, insofar as that quality lived in them which was organic, as did all other architectures possessing it. Greek architecture knew it – not at all! It was the supreme search for the elegant solution. Working with apprentices as I do, I have observed that when this idea of architecture as organic begins

⁸ Frank Lloyd Wright and Andrew Saint, *An Organic Architecture the Architecture of Democracy* (London: Lund Humphries, 2017), 18

to work in the young mind something happens: something definite happens to life. Something larger happens to one's outlook upon life. One becomes impatient of these unfounded restraints, these empirical impositions, these insignificant gestures as in grand opera, these posturings which all the buildings of the pseudo-classic and pseudo-renaissance assume to be art and architecture. One begins to want something a little nearer to the ground, more of life not so much on it. We begin to want to live like spirited human beings."⁹ -Frank Lloyd Wright

⁹Frank Lloyd Wright and Andrew Saint, *An Organic Architecture the Architecture of Democracy* (London: Lund Humphries, 2017), 29.

Usonia: Concept to Reality

Purpose

It is vital to understand Frank Lloyd Wright's Usonian concepts to understand fully the importance of these homes and why their preservation is key to the understanding of American architecture for future generations.

Additionally, understanding the circumstances in which these homes came about will help in understanding why the building materials and systems were chosen for these homes and subsequently, understand how and why these same materials and systems degrade.

As such, this section will explore the historical context in which the Usonian concept developed, Wright's personal beliefs and philosophies regarding this style of home, their design, the materials that make up these homes, and the systems found within them.

Usonia: A Definition

Usonian homes were Frank Lloyd Wright's answer to moderate cost single-family housing in a time when economic depression and World War necessitated more humble homes at prices which the average American could afford. These homes were small in size, but unique in style, utility, and sense of place. Usonian homes embodied Wright's ideas of Organic Architecture, his love of nature, his style of designing using a unit or module system, the expressed nature of the building materials and means, and his thoughts on how one should live in their home.

Usonian homes were designed for a variety of geo-temporal locations and span the United States. Today, many are privately owned, but a few are publicly toured. These homes are important not only in understanding Wright's architecture, but also facilitate a greater understanding of the period in history in which they were created and how, today, we mimic much of the concepts from these homes.¹⁰

Historical Background

The first official Usonian home was built for Herbert Jacobs in 1936 in Madison, Wisconsin. This was in the late years of the Great Depression. The Great Depression was a worldwide economic depression that affected most of the industry within the United States and around the world. Beginning in 1929, the depression did not officially end until 1941. The early part of this period saw a drastic decrease in construction and a plummeting of wages. This, in turn, decreased the cost of materials.

In 1933, Franklin Delano Roosevelt was elected President of the United States and offered a solution for this economic hardship by putting skilled people back to work. Out of Roosevelt's New Deal came what is often referred to as "alphabet soup agencies". Examples of the government agencies created include Works Progress Administration (WPA), Civilian Conservation Corps (CCC), Home Owners Loan Corporation (HOLC), Public Works Administration (PWA), and the Federal Housing Administration (FHA).¹¹

¹⁰ Bruce Brooks Pfeiffer and David Larkin, *Frank Lloyd Wright: Master Builder* (London: Thames & Hudson, 1997), 102-103

¹¹"FDR's Alphabet Soup," Ushistory.org, accessed November 13, 2017, <http://www.ushistory.org/us/49e.asp>.

All these agencies were meant to get people back to work and assist people in finding or building adequate housing. Affordable housing began to be a topic of conversation during this period and into the 1940s and 1950s there were several patterns that paved the way for affordable homes. Solutions to this problem were suggested both within cities and in the new suburban neighborhoods.

In 1941 the Levittown concept came into being, which is an archetype of affordable suburban living. The next decade saw the beginning of “white flight” to the suburbs, making them increasingly populated.¹² This shift from crowded city living to a desirable home in a suburb with a small yard, a fence, and a driveway became the new “American Dream”.

Of course, another worldwide event occurred during this period: World War II. Men went off to fight, while women and children remained at home. When men returned, they received their GI bill, a new law that protected soldiers returning from war and gave them assistance in assimilating back into society. Many men received assistance in purchasing or building a home – typically an affordable single-family home in a suburban area.

These events led to a new way of thinking about the city, housing, and the way in which people lived. The American ideal switched from the city to a plot of land with houses in a row, a way of living that will be exemplified in Wright’s Broadacre City. Wright, in the early stages of these events, was beginning to think about an affordable house for the common man. But, of course, Wright’s affordable designs were not something that can be likened to a Levittown

¹² Joshua Ruff, "Levittown: The Archetype for Suburban Development," HistoryNet, June 22, 2016, , accessed November 12, 2017, <http://www.historynet.com/levittown-the-archetype-for-suburban-development.htm>.

home, or even be truly compared to it, as he instilled his architectural philosophies and personal beliefs into these homes.

Wright began to cater to these returning G.I.s and developed his Usonian Automatic ideas with them in mind stating, "I have given it to him and he doesn't know it...in what I call the Usonian Automatic, where the union has been eliminated; where masonry at \$29.00 a day is out; where there are no plasterers at the same rate; where there are not carpenters at all. It is a block house. I did it for the G.I.'s. The G.I. can go in his back road...he's got sand there...get himself some steel rods and cement, make the blocks, and put the blocks together...I have done that thing...you can build your own house!".¹³

Getting to Usonia: Wright's Path to His American Ideal

Frank Lloyd Wright was raised by a family of liberal thinkers in a rural and beautiful area. This upbringing influenced Wright throughout the rest of his life. Wright, on average, rejected the city and wanted to design a "decentralized" way of living that was more connected to the land, but simultaneously centric to the automobile. Throughout the first part of Wright's career, he primarily designed for the wealthy. Later in his career he turned his attention to designing for the common man and wanted to develop a home that was affordable and that fit within his

¹³ John Sergeant, *Frank Lloyd Wright's Usonian Homes: Designs for Moderate Cost One Family Homes* (New York, NY: Whitney Library of Design, 1976), 144.

organic architecture ideals. He stated that, "The house of moderate cost is not only America's greatest architectural problem, but the problem most difficult for her major architects."¹⁴

The previously discussed historical events set the stage for Wright to expand upon his theories on the way in which American's should live and develop his Usonian designs. These homes would be affordable for the middle class and be keenly in-touch with the landscape and the ways in which Wright felt that families should live.

Broadacre City: A Plan for Decentralization

Wright had been thinking about designs for a new type of city, one that he called Broadacre City. This concept included an acre of land for every family, that centered primarily around the automobile. In Mark Pimlott's article on the subject, he compares Wright's Broadacre to Jeffersonian ideals and harkens the concept back to a homestead society.¹⁵

¹⁴ John Sergeant, *Frank Lloyd Wright's Usonian Homes: Designs for Moderate Cost One Family Homes* (New York , NY: Whitney Library of Design , 1976), 11.

¹⁵Mark Pimlott, "Frank Lloyd Wright & Broadacre City (2007)," Art Design Cafe, , accessed November 12, 2017, <https://www.artdesigncafe.com/Frank-Lloyd-Wright-2007-1>

There are parallels to be drawn to a Jeffersonian ideal. Very much in line with the Transcendentalist movement, the Jeffersonian ideal included a “return to nature” and a rejection of the urbanized and industrialized city centers. Wright did not care for cities and in fact turned his back on them largely to live two separate rural areas with a sprawling landscape, which was typically only accessible by car. Wright’s design elements and the focus that is placed



Figure 1 Image of Broadacre City Model
Source: Metropolismag.com

on them are even compared, by Pimlott, to a “frontier” mentality including a central hearth where families were meant to gather.¹⁶

¹⁶ Mark Pimlott, "Frank Lloyd Wright & Broadacre City (2007)," Art Design Cafe, , accessed November 12, 2017, <https://www.artdesigncafe.com/Frank-Lloyd-Wright-2007-1>

Broadacre City, while never realized, defined Wright's philosophies behind Organic Architecture, and what's more, an organic society. The decentralized plan focused on the independence and the new way of living of what Wright called the Usonian people.

Usonia: A Planned Community

This idea of a home with a plot of land that is accessible by car was something that Wright expanded upon. While Broadacre was never realized, Usonia, New York, a commune style community was. David and Priscilla Henken, founding members of Usonia, had just visited the Museum of Modern Art's exhibit that included Wright and his Broadacre City model. This was a way of life they were looking for – a communal style of living in an area away from the hustle and bustle of New York City.

Usonia was begun with thirteen interested families in 1944.¹⁷ As stated by Ronald Resiley, author of a book on Frank Lloyd Wright and an original owner of a home designed by Wright in Usonia, "Usonia's goal was to build such a community of individually designed, cooperatively owned, affordable homes on at least one-acre sites in a suburb of New York City with guidance and participation by Frank Lloyd Wright".¹⁸

Not all the homes in Usonia were designed by Frank Lloyd Wright, however, all are in keeping with Wright's Usonian concepts. The plots of land are circular, and blend into one another, a key factor in the cooperative aspect of the community.¹⁹ The original thirteen

¹⁷ Roland Reisley and John Timpane, *Usonia, New York: building a community with Frank Lloyd Wright* (New York: Princeton architectural publications, 2001), 9.

¹⁸ *Ibid*, 10.

¹⁹ *Ibid*, 26.

members interviewed potential members of the community to ensure compatibility in lifestyle and in style of homes. Originally, forty-seven families built homes in Usonia, New York.²⁰

Usonia was not the only cooperative style of community that Wright was involved with. In Detroit, Michigan, Wright helped to develop plans for a community of cooperative homesteads for the Detroit autoworkers. This plan was based on self-sufficiency, and included as key features of the home, a workshop, and an area to store dry food. The homes were set into the ground in a berm-style, utilizing the ground as a natural insulator. The community itself was set up much in the same fashion as Usonia, or along the concepts of Wright's Broadacre City.²¹

Wright's Philosophy Behind Usonian Homes

Frank Lloyd Wright's Usonian homes reflected his ideals on what America should be. He felt that American's should have a truly American style of home in the face of the International Style becoming more popular within the United States.

Even more, Wright felt that the solution to the hardship felt during the Depression was a way to be self-sufficient. Wright was living this self-sufficiency at his homes at Taliesin and Taliesin West.²² Wright developed this idea of self-sufficiency further with his planned community, all which had enough land for small planting and often included a communal garden. This concept eventually spilled over into his choice of Usonian clients, who were young

²⁰ Ibid, 10.

²¹ John Sergeant, *Frank Lloyd Wright's Usonian Homes: Designs for Moderate Cost One Family Homes* (New York , NY: Whitney Library of Design , 1976), 76.

²² John Sergeant, *Frank Lloyd Wright's Usonian Homes: Designs for Moderate Cost One Family Homes* (New York , NY: Whitney Library of Design , 1976), 38.

idealistic professionals who wanted to live away from the crowded cities. Wright preferred these clients as they built in areas with ample land, in a more suburban area, and were open to new ideas for design, which included a zoned home that fit into the new family lifestyle.²³

That lifestyle was one that is most keenly evident in the post-war Usonian, where families were moving into suburban areas that were, despite the ideal one-acre plot, becoming denser. Wright wanted to give privacy to the family and achieved this well with his unique clerestory window front façade and the open wall of glazing often seen on the back wall, connecting the home to the landscape.

Wright also zoned his Usonian homes, giving specific family spaces and putting emphasis on the central hearth around which the family was supposed to gather.²⁴ Wright wanted to bring to life a model that could be adapted for different landscapes, climates, and growing families. As such, this model was one that was highly successful for its functionality, economical nature, and its versatility to grow and change with the family's needs.

²³ Ibid.

²⁴ John Sergeant, *Frank Lloyd Wright's Usonian Homes: Designs for Moderate Cost One Family Homes* (New York, NY: Whitney Library of Design, 1976), 30.

Usonian Forms: Module and Unit System

Wright's Usonian homes implemented several interesting ways of designing and construction techniques, which are nearly singular to these Usonian homes and give a guideline for identifying them, as well as understanding homes that are designed from this philosophy.

One unique factor of these homes was Wright's use of the grid system in the design. While used in his Prairie homes as well, they became simplified and reflected in the concrete floor of the Usonian designs. In the early Usonians, these grids were often 2 feet by 4 feet, or some other simple unit of measure.²⁵

This grid or module was the perfect design system for the Usonian homes as they were often based on typical material sizes, such as plywood sheets or 2x4s. Additionally, it helped with the design process in easily adding or subtracting space within the design scheme and created an easy to use guideline for the contractors who were building these homes.²⁶

The grid was a unit of measure, and the module of the home was typically based from a geometric shape. The early homes were rectangular modules, which were mimicked in their overall forms, but later Wright moved into more intricate shapes such as the hexagon and the circle.

Wright's Usonian homes can typically be categorized into five basic types of plans. These make up the standards from which variations can occur.

²⁵ John Sergeant, *Frank Lloyd Wright's Usonian Homes: Designs for Moderate Cost One Family Homes* (New York, NY: Whitney Library of Design, 1976), 19.

²⁶ John Sergeant, *Frank Lloyd Wright's Usonian Homes: Designs for Moderate Cost One Family Homes* (New York, NY: Whitney Library of Design, 1976), 19.

The first type, and most common, is the Polliwog. This type is characterized by a rectangular design scheme that employed the 2x4 foot plan, or grid. This can be seen typically as an “L” or “T” shaped plan, with the “L” shape being the more common.

A polliwog is something of a tadpole, and as such, has a head and has a tail. This metaphor is useful in visualizing Wright’s zone system for his homes. The head of the polliwog is the living room and can include the kitchen and dining space. The tail of these homes is characterized by the private spaces - the bedrooms and bathrooms. These homes feature 90-degree angles.

The second form is the Diagonal Usonian, a variation on the Polliwog design. This slight change adds in a 45-degree angle system at some sections, which opens up spaces and makes for a defined zoned system, as well. The most well-known house in this form is the Marcus house in Dallas, Texas.²⁷

The In-line design is one that employs a less defined zone plan, which is more clearly delineated in the Polliwog homes. This design is often more compact than other Usonians and is described by Seargent in his book on the subject as a “single block” plan.²⁸ Examples of these homes are the Sturges Home, the Winkler-Goetsch Home, and the Baird Home.

²⁷John Seargent, *Frank Lloyd Wright's Usonian Homes: Designs for Moderate Cost One Family Homes* (New York, NY: Whitney Library of Design, 1976), 51.

²⁸ *Ibid*, 52.

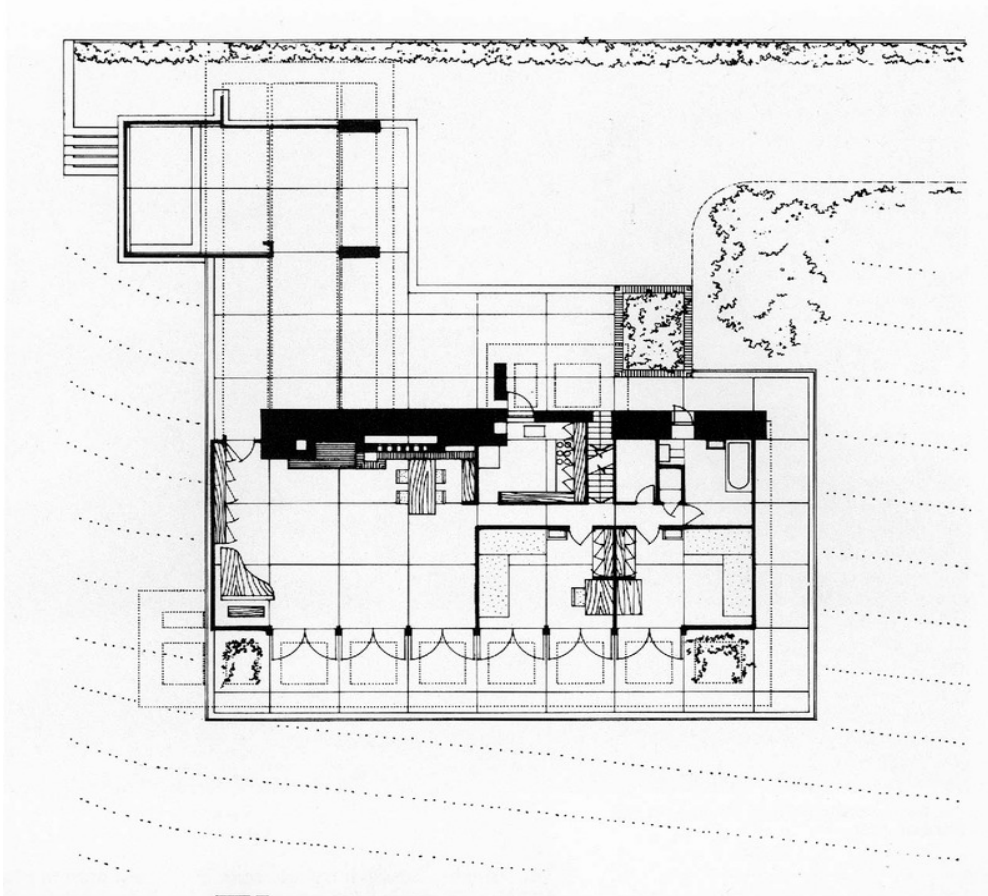

Fig.2 Sturges Home Plan
Source: University of Buffalo Archive
<http://digital.lib.buffalo.edu/items/show/30753>

The fourth type of Usonian home is the Hexagonal Usonian, which is exemplified most clearly in the Hanna House, also referred to as the honeycomb house. Wright began experimenting increasingly with different shapes and thought about how utilizing these shapes as modules would affect the inhabitant. Wright felt that the angles in a hexagon were more

conducive to human movement than a strict 90-degree square system.²⁹ Actually, the hexagonal design is based both on the triangle and the hexagon and features the angles 60 and 120.³⁰

Many hexagonal designs feature the roughly “L” shape featured in the polliwog style and convey a clear sense of public and private space; however, they move the inhabitant in a different way from space to space.

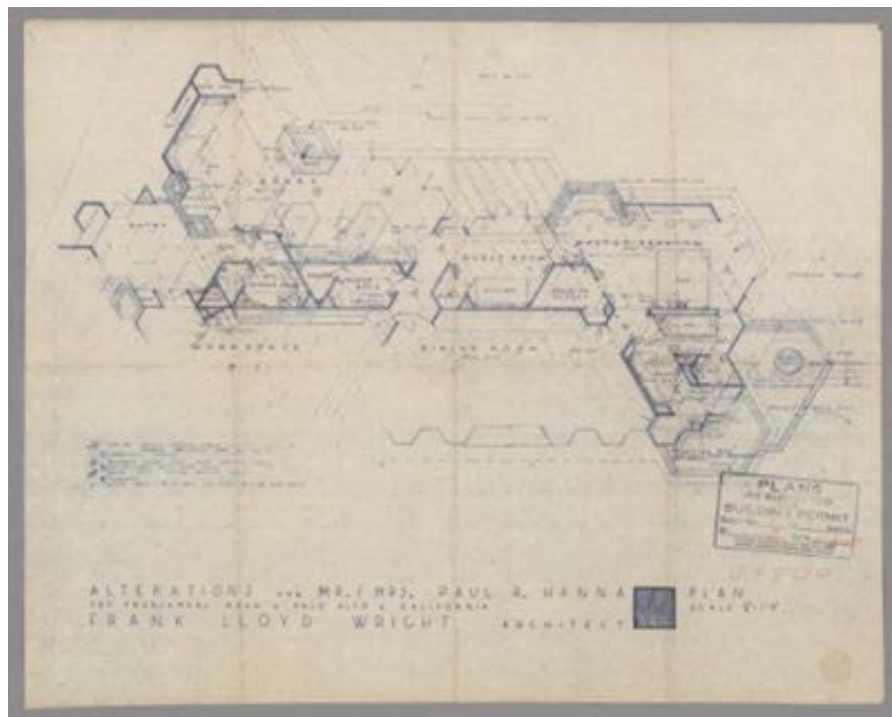

Fig. 3 Plan - alterations for Mr. & Mrs. Paul R. Hanna (No. 149 with Building Dept. submitted stamp.)

Source: Stanford University Libraries

²⁹ Frank Lloyd Wright and Andrew Saint, *An Organic Architecture the Architecture of Democracy* (London: Lund Humphries, 2017), 61

³⁰ John Sergeant, *Frank Lloyd Wright's Usonian Homes: Designs for Moderate Cost One Family Homes* (New York, NY: Whitney Library of Design, 1976), 32.

While the Hanna House was the first, the Auldbrass Plantation is another example of hexagonal planning, as is Kentuck Knob. The angles of the home oftentimes form severe triangular points and sharp curves; however, the homes do seem to envelope the inhabitant and very clearly move them through the spaces.

The Raised Usonian homes are the next and final example of types of Usonian homes. These homes are typically built on masonry piers that elevate them above or assist them to be built into their landscapes. This system used the masonry piers to support the cantilevered section of the home that juts out over a ravine or body of water. These homes are small and efficient and typically are most like an in-line plan Usonian in overall shape.³¹

³¹ John Sergeant, *Frank Lloyd Wright's Usonian Homes: Designs for Moderate Cost One Family Homes* (New York, NY: Whitney Library of Design, 1976), 68.

Common Building Materials and Elements

While Usonian homes vary in material and building systems, typically, there are defining features and common elements that can assist in identifying this type of home.

Usonian homes, as an affordable answer to housing, featured simple and typically easy to acquire building materials. These materials include wood, glass, concrete, brick and/or stone. Of course, these are over generalized ways of discussing the materials which will be explored further in this section.

Wood was common to nearly all Usonian homes. In the early years of Usonians many of them featured cypress, a wood that, if old growth, is naturally rot and termite resilient, as Wright considered this to be a superior building material. Other common woods include redwood, mahogany and cedar, but the wood types vary by material availability, cost and location.

Wright uses a reverse board and batten system in his Usonian homes to form the exterior of his “sandwich walls”, a common feature in these homes. The sandwich wall consisted of two board and batten walls with building paper on the interior of these and plywood as the core. This provided for an inexpensive wall system.³²

Building paper is a thin waterproof and airtight material that is an added layer of protection for a home. It is meant to provide protection from air and water infiltration into

³² Bruce Brooks Pfeiffer and David Larkin, *Frank Lloyd Wright: master builder* (London: Thames & Hudson, 1997), 120.

homes, and, alternatively, to keep moisture inside in cases of air conditioning. Often, a primary material in building papers of this time was asphalt.

Concrete was used in Usonian in three primary ways. These uses include as a footer, as a poured floor material, and as a cast stone in the form of Wright's textile blocks. One of these home's typical character defining features was the Cherokee red concrete floor that would often have the grid or module of the home etched into it.

Brick was another common building material. Often these homes are of primarily masonry construction. Brick typically would have been manufactured locally and, as with all building materials, would have been present both inside and out. This was much more common than stone, as stone would usually have been the more expensive choice of the two. Despite this cost, some Usonian homes do feature stone as their primary masonry material. This typically would be sandstone or something comparable.

Large spans of glazing, or glass, was another important part of Usonian homes. Glass and its orientation was vital to Frank Lloyd Wright's architectural philosophy. Walls of glass typically were found on the Southern and Eastern sides of homes, taking advantage of the sun on those elevations.

A Note on Sustainability

Frank Lloyd Wright was truly before his time when discussing the modern day hot topic of sustainability. Sustainability is usually defined as the ability to continue or maintain over a long period of time, which in an environmental sense involves the way people live their lives and the choices they make on a day to day basis.

Usonian homes are very early examples of sustainable design. Their local builders, local and natural materials, small physical footprint, and the use of the landscape and orientation of the sun for natural temperature regulation make-up only some of the ways in which these homes exemplify energy and material conservation.

These homes can serve as examples of how to think about building in a local and sustainable way. Through the act of careful and methodical preservation tactics these homes can not only stand as testaments to the theory that the greenest home is the one already built, but as teaching tools for ways in which the homes we live in can be sustainable.

Chapter 3

Case Studies in Preserving Usonian Homes

Purpose

In order to understand the complexities of, and variations within these Usonian homes several case study homes were chosen. All of the case study examples have undergone major restorations that are in-line with the common preservation issues found in the Homeowner's and Public Sites survey, to be discussed in great detail in the section following this.

These homes represent the variety of styles, forms, and materials that make-up these beautiful homes. The case study homes exemplify the importance of continued maintenance and magnify the oftentimes numerous issues that can occur within a home simultaneously and throughout its lifetime.

Case Study Home

Home: Herbert Jacobs House

Location: Wisconsin

The Herbert Jacobs House was built in 1936 in Madison, Wisconsin for Herbert Jacobs and his wife, Katherine. The Jacobs' home was the first true Usonian home designed by Frank Lloyd Wright and subsequently set the precedent for all future designs.

The prototype home was a simple 1150 square foot L shaped plan, designed on a 2 ft by 4 ft rectangular module at a total cost of \$5,500 – an affordable price for the middle-class Jacobs' family. The home sits on the corner of the lot, with south facing French doors that give

access to the terraces and gardens.³³ As stated earlier, it was vital to Wright that each of his Usonian homes be designed in harmony with the landscape. This is evident in the thoughtful siting of the house on the property.

The home's board and batten interior and exterior "sandwich" walls are Ponderosa Pine (board) and Redwood (batten). The brick piers and walls are the main structural support for the home. Brick is also the material that forms the masonry core of the home that houses the kitchen and divides the public and the private sections of the house. The ceiling heights of the home vary and are higher in the living and dining areas and lower in the private spaces. The higher ceiling heights allow for clerestory windows. The Jacobs' house does not feature a perforated design, however, the street facing clerestory windows provide strategic light infiltration, as well as privacy.³⁴



Fig.4 Image of Herbert Jacobs House Photo by Joe Koshholleck

The Jacobs House is now just over 80 years old and is currently owned by James Dennis, who purchased the home in 1982. The home underwent a large-scale restoration project after Mr. Dennis purchased it. As the prototype Usonian, the Jacob's home exemplifies the common building elements and

³³ Doreen Enrich, *Usonian Houses: Frank Lloyd Wright at a Glance* (London, UK: PRC Publishing, 2002), 30.

³⁴ Bruce Brooks Pfeiffer and David Larkin, *Frank Lloyd Wright: master builder* (London: Thames & Hudson, 1997), 30.

materials of this type of home, as well as the typical preservation issues that arise.

Jacobs Restoration

Radiant Heat

The house features an 8-inch floating poured concrete floor above 1 ½ inch welded steel piping over an 8-inch sand bed. This steel piping makes up the radiant or gravity heat for the home, through which hot water runs from the boiler in the basement. When the system was put in place, there was no insulation placed under the concrete and, therefore, the heating system was relatively inefficient.

When Mr. Dennis took ownership, he realized that the system was failing in the living and dining areas of the home. As the piping is under the concrete, the slab flooring needed to be removed by jackhammer and the failing steel pipe cut out.

Modern flex tubing was chosen to replace the failed steel system. A new slab was poured with flex tubing 2 inches below the surface of the slab. In addition to this system, the boiler was replaced with a high efficiency model.³⁵

Take Away

This is the first introduction to one of the most prevalent issues in Usonian homes. Due to the under or in-floor nature of this type of radiant heating, often it is necessary to remove the existing flooring to fix or even identify leaks, which can be a costly endeavor. Materials for this type of heating at the time were primarily various types of metals (usually copper, steel, or

³⁵ Bill Martinelli, "Jacobs House I Interview," telephone interview by author, September 18, 2017.

iron) allowing for corrosion over time. This corrosion causes weak points for small cracks or holes. Different types of metals deteriorate at different rates. It is important to understand the construction method and material in a system for potential mitigation and proper maintenance. Later in this paper are case studies and information about different construction methods, existing materials, and options for replacement or repair.

Roof

The Jacobs' house, as with many of Wright's designs, featured a flat tar and gravel roof. The original roof was three layers of built-up roofing surfaced with asphalt felt. The roof line rises higher over the living room and dining room than in the private sections of the home.³⁶

The roof leaked in multiple places throughout the life of the home, and over the years, increasingly more layers of tar and gravel were put over the original layer as an effort to remedy these leaks. This continual layering resulted in approximately 4 inches of material over the flat and cantilevered sections of the roof. The resulting weight of this caused undue stress on the roof truss system. The original roof truss system was made up of 3 2x4s stacked on top of one another. This "sistering" of materials was a cost saving effort on Wright's part, but it proved to be insufficient support for the roof over time.

By the time of the restoration, the roof needed to be rebuilt. Steel beams were included in the cantilevered sections of the roof to provide needed structural support to the failing roof

³⁶ Doreen Enrich, *Usonian Houses: Frank Lloyd Wright at a Glance* (London, UK: PRC Publishing, 2002), 15

sections under the weight of the tar and gravel. The tar and gravel was completely removed from the home and a rubber membrane roof was chosen to replace the old material.³⁷

As with all flat roofs, water collection and retention are an issue. To deal with water pooling on the roof, the restoration architect decided to slightly pitch the roof to allow for better drainage. This would also increase the ease with which snow load would be removed from the roof.

Take Away

Proper roof drainage is key to mitigating the damaging effects of water retention, which can cause stress from the weight of the water in both liquid and solid form as well as rot if water is allowed to penetrate roof material. The architect's decision to add pitch to the roof would not negatively affect the overall aesthetic of the roofline, as much of it would not be visible from street level. In some homes, this may be a necessary solution for continual roof problems. An architect should be consulted if this type of intervention is necessary. It is important to consider the degree of pitch and how that will or will not affect the aesthetic and integrity of the home.

Exterior Woodwork

The exterior woodwork is the typical board and batten construction. What is unique about this home is the differing materials within that system; the boards are 9-inch-wide ponderosa pine and the battens are 3-inch-wide redwood.

³⁷ Bill Martinelli, "Jacobs House I Interview," telephone interview by author, September 18, 2017

The major preservation concern when Mr. Dennis took over stewardship of this home was the existing coating of black creosote covering the exterior woodwork. It was imperative to remove this material. The product chosen to remove the creosote was a stripper made by Osmo, a German company. It was described as extremely effective by the owner and caretaker.

The south facing facade of the home receives significant direct sunlight in addition to general weathering, which breaks down the finish on the woodwork. It is necessary to refinish this side of the home on a more regular basis.

In addition to the board and batten exterior walls, the south-facing window wall faced similar issues. The entire window wall was replaced during Mr. Dennis' ownership due to the bottom door rails rotting. The rot was significant because the home is slab on grade, and water was retained at this section. This is something that is also an issue at Kentuck Knob. The bottoms of the French doors on the southern façade are discolored due to moisture. When the glazing wall in the Jacobs house was being replaced, thermal glass was introduced into this portion of the home. Eventually it was decided to upgrade most of the glass in the home.³⁸

Take Away

An important concept in preservation is that of reversibility. As time passes, technology changes, and knowledge increases there are new and better ways of dealing with certain issues in homes. Today, preservationists and conservationists deal with previous pathologies and their potential negative effects on a building. One example was the common thought that a Portland cement coating was an ideal way to fix existing damaged masonry walls or mortar joints. Today,

³⁸ Bill Martinelli, "Jacobs House I Interview," telephone interview by author, September 18, 2017.

we know that Portland cement is typically damaging to historic masonry, but that was not known during the time it was introduced.

The Jacobs' home example of black creosote coating the woodwork is a great lesson in remedying an outdated and improper method of building conservation. Sometimes, these older pathologies can be extremely damaging to historic material and not reversible. It is because of this understanding, that all future preservation work should be reversible, as in the future a more effective method could be discovered.

Continued Maintenance Plan

As the Jacobs House is over 80 years old, a maintenance plan is prudent for this and all Usonian homes. The current owner is keenly aware of this importance. The South and East facing facades receive wood restoration every two years. This is in keeping with many Usonian homes, as these are the facades which receive the most weathering. The floors are Cherokee Red colored concrete, which historically were waxed with Johnson Wax – specified by Frank Lloyd Wright. Approximately every two years the paint on the floor needs to be redone.³⁹

³⁹ Bill Martinelli, "Jacobs House I Interview " telephone interview by author, September 18, 2017.

Home: Kentuck Knob - I.N. and Bernardine Hagan House

Location: Chalk Hill, PA

Kentuck Knob History

Kentuck Knob is a single story 2200 square foot Usonian home designed for I.N. and Bernardine Hagan in 1953. The Hagan family, friends of the Kaufman's of Uniontown, were lifelong residents of Uniontown, PA, and upon falling in love with Frank Lloyd Wright's architecture purchased an 80-acre tract of land in a nearby rural mountainous area in order to build a Wright designed home.

Wright, when he began this project, was 86 years old and a very busy man. As such, he designed Kentuck Knob sight unseen from topographical maps and aerial photographs of the property.

Construction was completed in July of 1956 and the Hagan's moved in immediately. When discussing typical Usonian homes, it is important to note that this home is significantly larger and with a higher cost than what would be considered average for a Usonian. In total, the home cost 96,000 dollars; a far cry from their desired 60,000-dollar budget. Additionally, the home is 2200 square feet, which is larger than typical.

The home was designed on a hexagonal module, with angles of 60 and 120 degrees accentuating this form. Only two 90-degree angles exist within the home, and each are in the bathrooms, at the request of the plumber. Not typical of Usonian homes, this house features a

small basement where the Hagan's stored extra food for the winter and that housed the washer and dryer, water heater, and boiler.

The exterior materials of the home are mimicked on the interior, a method through which Wright conveyed his ideas of organic architecture. Wright wanted to bring the exterior landscape into the home and accomplished this in many ways. This idea of organic architecture is exemplified most effectively at Kentuck Knob through the home's relationship to the landscape; Kentuck Knob is built into the hillside and, from some views, appears to be ship emerging from the hill.

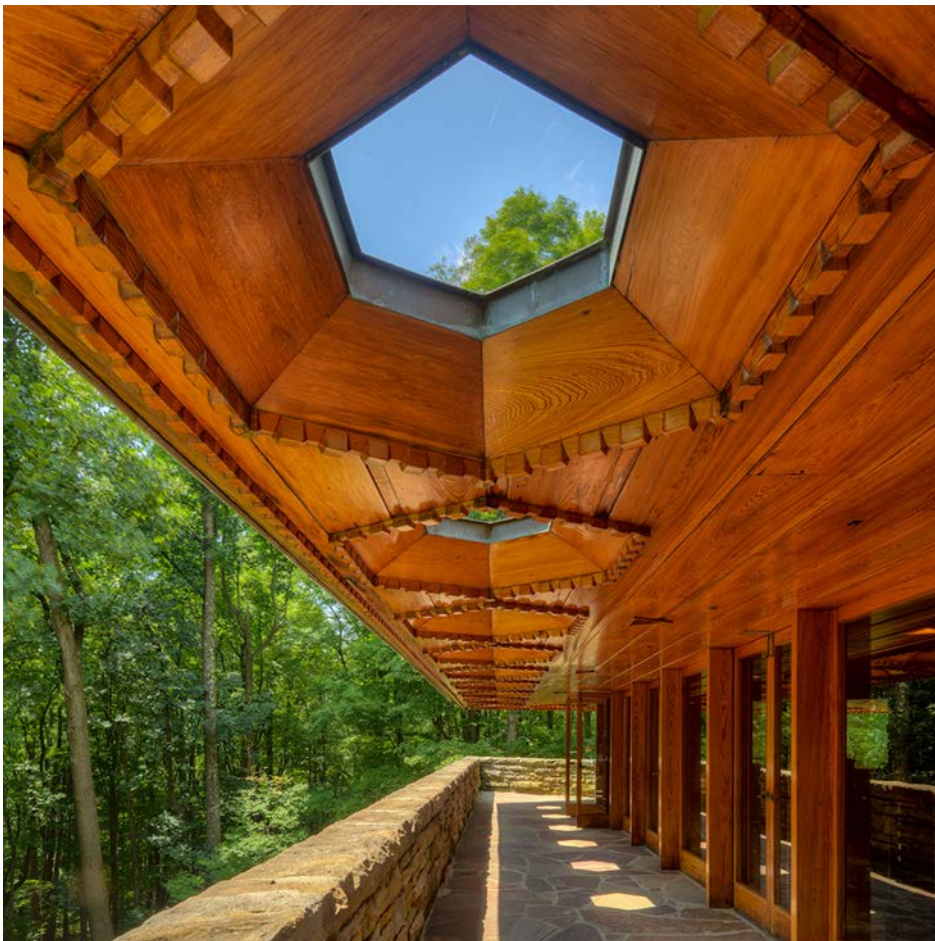

Fig. 5 View of Southern Terrace of Kentuck Knob
Source: kentuckknob.com

Construction, Materials, and Systems

The roof on the main portion of the home is copper, another common Wright material, and is pitched at a 20-degree grade for efficient precipitation shed. The carport, art room, and terrace have flat roofs with a gravel ballast roof system.

The woodwork is Tidewater Red Cypress, a wood that Wright admired and used often in these later Usonian homes. He referred to this wood as "the wood eternal", as it has both rot and termite resilient qualities. This wood was sourced from the Gulf South and was shipped to Pennsylvania for the project.

The major exterior material and the structural element for the home is stone. The stone is local Pottsville Sandstone and was cut from large boulders found on the property and dressed to appear as if quarried. The exterior wall system is made up of two stone walls with two inches of black foam insulation in-between.⁴⁰

A concrete footer was poured, serving as the foundation, and accepting backfill to level the house into the hillside. On the north wall, 2x12 support beams are built into the stone work for support and on the southern wall, steel beams are utilized to support the glazing and the cantilevered roof section. The roof does cantilever over the southern terrace significantly; the weight carried by the steel support beams and the roof structure.

⁴⁰ Bernardine Hagan and Frank Lloyd Wright, *Kentuck Knob: Frank Lloyd Wright's House for I.N. and Bernardine Hagan* (Pittsburgh, PA: Local History Co, 2005), 47.

The home features a relay electrical system, which has since been overwritten and new switches added in the basement. As a part of this relay system, the master bedroom featured master light controls for the home.

The heating system is what Wright referred to as gravity heat. This system is comprised of 2200 linear feet of cast iron pipe running in a loop under the floor. Hot water is run through the pipes that is heated by an oil boiler.

The first layer in the radiant heat system is several inches of blue stone chips with angle iron over top. This angle iron system is what is holding the pipes in place, which rest on the iron sections and are welded together. A floating concrete subfloor was poured over the iron piping and the flagstone installed over this.⁴¹ This complex system is something that Wright used in most of his Usonian homes, with slightly varying methods of installation.

Preservation Projects

Woodwork

The tidewater red cypress, as stated earlier, makes up the interior and exterior woodwork including the doors and windows. This wood was treated by the Hagan's with a spar varnish that was made by Brenner Brothers. Frank Lloyd Wright did not want the exterior wood to be treated, as he favored a natural weathered look, however, the Hagan's had learned from Llewellyn Wright that the cypress, if left untreated, would turn a dark gray or black and crack.

⁴¹Bernardine Hagan and Frank Lloyd Wright, *Kentuck Knob: Frank Lloyd Wright's House for I.N. and Bernardine Hagan* (Pittsburgh, PA: Local History Co, 2005), 47.

Thus, they treated the wood, which is a tradition that is continued today. The interior was treated with Satinlac, also by Brenner Brothers, to give it a soft shine.⁴²

As the exterior wood was treated, it has remained prudent to continue to treat this wood with similar materials as the varnish will, over time, delaminate. This varnish deterioration from weather exposure is the cause for the following restoration projects.

Front Screen Door

Toward the end of 2014 the front French screen doors of Kentuck Knob were beginning to show signs of discoloration and delamination of the finish toward the lower section of the doors. Additionally, the bronze screen was becoming loose and fraying at the connection point of the door trim. As a focal point of the home, it was decided that the doors should be refinished. A restoration carpenter was located from Pittsburgh, Pennsylvania, who specialized in small finish carpentry work - Starz Interior Restoration.

Mr. Starz took the doors to his workshop in Pittsburgh. Due to the discoloration and delamination of existing varnish it was chemically stripped from the doors and the entirety of the doors sanded, as far as was reasonable to achieve relative color continuity. Mr. Starz then recoated the doors with three coats of spar varnish and replaced the bronze screen with new. Additionally, new Baldwin brass hinges were located and replaced. The new hinges had a lacquer that was not appropriate to the original nature of hardware. These hinges were sent

⁴²Bernardine Hagan and Frank Lloyd Wright, *Kentuck Knob: Frank Lloyd Wright's House for I.N. and Bernardine Hagan* (Pittsburgh, PA: Local History Co, 2005), 56.

out to Frank Mance Plating Service in Pittsburgh, PA to chemically remove this lacquer and to lightly polish the brass hinges.⁴³

Take Away

The most vital take away from this preservation project was the importance of finding a sensitive and thorough finish carpenter. As discussed in the introduction, this thesis topic comes from the author's own experience with learning on the job the best practices for preserving Usonian homes. This was one of the first projects handled by the author. As such, the most difficult part of this project was sourcing a carpenter who would use appropriate materials and be sensitive to the historic integrity of the home and the doors.

South-Facing Fascia and Windows

The southern facade of Kentuck Knob, on the southeastern side, consists of a series of casement windows that peers into the dining room. On the southwestern side is an overhang with hexagonal skylights punched in the flat cantilevered ceiling. This overhang shields the southern terrace and its wall of French doors that lead into the living room.

As this is the southern wall, it receives significant and direct weathering including sun and rain. This weathering has caused more noticeable damage to the woodwork on this side in the form of cracking the varnish and exposing the raw cypress under the finish. Over time, under the pressure of rain, water has entered the wood and discolored sections of the window sill and fascia boards.

⁴³ Emily Butler, *Kentuck Knob Archive*, Preservation Records - Unpublished, Chalk Hill.

To be discussed later in greater detail, the roof system above this section is flat, with a new EPDM gravel-ballast roof system. Prior to this new roofing system being put in place, there was an issue with water damage from a tear in the previous EPDM system that had damaged some of the roof decking and the fascia/soffit. This caused an excess of moisture in the fascia boards, which are not properly ventilated, that found an escape when the varnish was removed during the refinishing process of these boards.

The previous finish on the cypress was failing, and so it was removed easily with carpentry scraping tools initially and the remainder with a random orbital sanding tool at multiple levels of grit to achieve a smooth grain and to remove most discoloration and varnish.

The windows were refinished with a product from PPG Paints Co. This product is Sikkens ProLuxe Cetol 1 RE and 23 PLUS RE. This finish is the same material that is used in the Reisley House to protect their cypress siding. The Cetol 1 RE is the base coat that penetrates the wood. It does not create a sealed barrier, but rather repels exterior moisture and allows excess moisture to be released. The second coat, Cetol 23 Plus RE, is a translucent top coat that provides UV protection by absorbing UV rays, which is vital for this side of the home.

This combination will allow any trapped moisture to release from the wood, while protecting against penetrating rain and stopping damage from direct sunlight. As this is the most vulnerable side of the home, with direct sunlight and prevailing winds, this coating will need to be maintained every two to three years.

This wood treatment was chosen for this specific type of wood, and individual treatments will need to be assessed and chosen based on location, sun exposure, weathering, and type of wood.⁴⁴

Take Away

The most important take away from this project is the importance of regular maintenance. It is imperative to keep up with protective coatings on cypress or any exposed wood. Once the protective coating fails, the wood, in this case cypress, will begin to turn a gray/black color and begin to check and crack.

This issue can be easily mitigated with regular maintenance coats of the material which is the most effective for the specific type of wood and finishes on the home.

Masonry

The home is primarily of masonry construction. The stone was locally sourced and is referred to as Pottsville sandstone. The double stone walls form the masonry core of the home, as well as the exterior walls. In addition to the sandstone wall, the floors of the home, save for the kitchen, are flagstone.

As a part of regular maintenance at Kentuck Knob, the mortar is re-pointed as needed. On average, the sandstone walls do not break down or need to be replaced, however, the flagstone entryway steps and landing are subject to weathering and chip or flake under freeze and thaw conditions.

⁴⁴Emily Butler, *Kentuck Knob Archive*, Preservation Records - Unpublished, Chalk Hill.

Re-Pointing of Exterior Stairs, Retaining Wall, and West Wall

In the spring of 2014, a significant amount of mortar loss and failure was noted on the front steps and landing of Kentuck Knob. This significant damage was due to, in large part, salt being placed on the stairs the winter prior in an effort to melt ice. The high concentration of salt in conjunction with the freeze and thaw of the already deteriorated mortar created an environment where both the mortar and flagstone were disintegrating.

The solubility of salts in the moisture in masonry materials changes as the water permeates through the material and eventually evaporates. When the moisture evaporates it causes the salts to crystallize and expand. These expanded salts are left in the masonry causing sub-florescence and eventually efflorescence (caused when the salts move to the surface of the masonry). This process can cause spalling or cracking of the material, weakening its structure over time.⁴⁵

This damage, exacerbated by the introduction of de-icing salts, was the main catalyst for the decision to hire a contractor to repoint the entrance stairs; however, there were other mortar failures and cracks that needed to be addressed.

On the west wall of the home, a large crack through the mortar joints was identified. The crack ran from the top of the wall, near the exterior planter, almost to the bottom of the house. Additionally, the low retaining wall across from the copper light also had several locations where the mortar was lost.

⁴⁵ Robert A. Young, *Historic Preservation Technology* (Hoboken, NJ: J. Wiley & Sons, 2008), 100.

Mariani and Richards, Inc. a well-known masonry restoration company in Pittsburgh, was chosen to perform the work. This company was chosen because they had previous experience with restoration masonry work including St. Pauls Cathedral in Pittsburgh and some work at Fallingwater, as well.

The most important aspect of this project was color matching the mortar. The company had done work previously at Kentuck Knob. In the early 2000s the entire flagstone floor was repointed. This project gave Mariani and Richards the unique advantage of already having experience with repointing this specific type of flagstone. As such, the same mortar mixture was used on this project.

They did come to Kentuck Knob for inspections a few times prior to beginning work to take a small sample to color match from. They needed to color match the mortar on the flagstone as well as the mortar that was used in the sandstone wall and retaining wall. This project was successfully completed with an appropriate color.

Currently, there are several sections on the front steps where the mortar is beginning to fail again. As the steps see a significant amount of foot traffic and exposure to extreme element changes, the steps require regular maintenance and re-pointing.⁴⁶

Take Away: A Note on Maintenance & Cleaning

While most Usonian homes do not have flagstone floors, adopting an appropriate cleaning regimen for any floor is something to consider. As such, a brief discussion on how to

⁴⁶ Emily Butler, *Kentuck Knob Archive*, Preservation Records - Unpublished, Chalk Hill.

determine an appropriate cleaning plan is discussed here in relation to the flagstone. However, this analytical process can be applied to all materials.

Maintenance and cleaning of flagstone floors is an important part of the overall maintenance plan at Kentucky Knob. The flagstone in the home is a silica sandstone at 97% glass, which is a non-porous type of stone. The make-up of the stone was taken into consideration when determining what type of cleaner to use. After a more thorough understanding of the material was had, the next step was requesting maintenance and cleaning plans from the quarry it was sourced from as well as other stone experts.

It was determined that a cleaner low on the PH scale was ideal to preserve the face of the stone. A diluted mixture of vinegar and water was a suggestion from multiple sources. This would serve to neutralize the stone and remove any residue that has accumulated on the floor over time. Additionally, a non-toxic cleaner such as Dawn dish liquid could be used.

This was the adopted form of cleaning the flagstone floors. Once a month the floors are cleaned with vinegar and water and once a week they are cleaned with one drop of Dawn dish liquid in a bucket of warm water.

Wright does use stone floors in his designs, and often the suggested finish was a Johnson Wax material. The Hagan family chose flagstone for their floors because they had seen them at Fallingwater and were not interested in a concrete floor, which is the more traditional choice in Usonian homes. The Hagan's also chose not to seal their stone floors with the same Johnson Wax as Fallingwater. Today, the stone is waxed once a year with a product called Bri-Wax, which is a 100% natural bees wax. Once a year, the floor is cleaned with a vinegar and

water mixture and the Briwax is buffed into the floor using cotton cloths and an Oreck buffer with a lamb's wool bonnet. This is an effective way to revitalize the shine and vibrant color of the stone, which will fade from the sun and constant cleaning.

The majority of the wax is absorbed into the stone and the excess is removed through buffing and cleaning. Over the course of the year the wax has either been absorbed or removed relieving the need of removing the previous coating of wax prior to the next application. The combination of these two methods, along with as-needed repointing, has kept the flagstone floors at Kentuck Knob in excellent condition.

It is prudent to understand the material first, and then to identify how potential cleaning agents will interact with or affect the material being cleaned. Researching materials and cleaners is an important step in creating an effective maintenance or cleaning regimen that will not harm the material over time.

Roof Repairs

As will be discussed later in greater detail later in this paper, roof failure and water intrusion are common and serious issues that many Usonian homes face. Kentuck Knob is no exception to this issue, which is one of the most difficult aspects of preserving the home.

The main hipped portion of the roof of Kentuck Knob is copper with a step system that follows the 20-degree slope of the roof and reinforces the horizontal nature of the home. There are 2x12 roof truss supports and tar paper under the copper exterior with ventilation in the cap. This system has no gutters, which is not uncommon in a Wright home, and merely facilitates water drainage from the edge of the sloped roof.

The skylight openings at the West and South portions of the house, and the carport and art studio all have flat roofs with gravel-ballast roof systems and 2 x12 roof support systems with decking covering the beams. These sections of the roof feature triangular copper downspouts that move water away from the roof. The pea gravel that holds down the ballast system is the medium through which this water is moved.



Fig.6 Kentuck Knob Carport Roof
Source: Kentuckknob.com

The other flat portion of the roof is the masonry core, which Wright labels the workspace and is today called the kitchen. The masonry core of the home is 14 ½ feet high and juts above the copper roofline. The kitchen features a large hexagonal skylight covered by a custom-made plexiglass dome. This masonry core has a 1 ½ foot parapet wall surrounding it with a flat EPDM roof system (no gravel on this section) surrounding the skylight and coming up above the parapet to seal at the edge. Flat or hipped roofs are common in Wright’s Usonian

homes, as are a combination of both. Additionally, it is common to see skylights, trellis openings, or the like.⁴⁷

Roof Replacement and Repair

The most recent and significant roof work performed on Kentuck Knob was the total replacement of both the carport/art room roof as well as the southern terrace roof. Each of these roof sections featured the rubber membrane roofing system combined with gravel to hold down the membrane.

Initially, it was decided to replace the carport roof due to evidence of water intrusion on the northwest corner of the carport fascia board. This evidence came on quickly and was significant. The wood was beginning to show signs of severe water damage and rot.

The existing 20-year-old EPDM roof was detaching at the edges of the roofline and the interior seams were beginning to pull away from each other. The entire roof was removed, followed by a thorough investigation of the roof structure. It was found that, on this same corner, was significant water damage to the truss boards and the decking. Some of these elements were replaced in the restoration process.

A new ballasted EPDM roofing system was chosen. This system is the 60-millimeter reinforced Genflex EPDM Membrane for Ballasted System. This system will be described in greater detail in following sections.

⁴⁷ Emily Butler, *Kentuck Knob Archive*, Preservation Records - Unpublished, Chalk Hill.

The terrace roof was replaced with the same material. Additionally, the corner section of this roof was showing signs of water intrusion and damage. When the roof was removed it was found that 6 truss beams were needed to be replaced along with four sheets of decking. What is unique about the terrace roof replacement is that the membrane is two long sections from which the skylights were cut out to eliminate seams, which are the first areas to break down in this roofing system.

Unfortunately, it seems as if water was still infiltrating into this section of the roof through the edge of this membrane which meet two pieces of copper flashing that form the edge of the roof system. It may be necessary to bring the EPDM past the edge of the flashing to form a better seal.

Another section of roof that continuously leaks is the kitchen roof, directly above the range in the kitchen. Recently, the vents for the fireplace and the range were replaced and the EPDM membrane surrounding them resealed.⁴⁸

Take Away: Troubleshooting

Determining the source of roof leaks and other roofing problems can be quite difficult as sometimes the leak is in multiple places, or the water travels laterally from the intrusion point to where it finally ends, or there is no visible evidence at all.

⁴⁸ Emily Butler, *Kentuck Knob Archive*, Preservation Records - Unpublished, Chalk Hill.

Additionally, it is often the case, as it was with the projects at Kentuck Knob, that once a roofing project is begun and the old roof removed there can be a larger, more serious problem underneath than originally anticipated.

Troubleshooting comes with dealing with any issue in a historic home and is part of the learning process. It is in this process that preservation, architectural, or engineering professionals can be invaluable to a project.

Sourcing Material: Hardware

The hardware in Kentuck Knob, including window cranks, door knobs, drawer pulls, and screen door handles and locks, are mostly original. These items are placed under great stress as they are continuously used for touring purposes.

Nearly all the hardware, in some form or another, is beginning to show signs of wear and are not operating smoothly or efficiently. The hardware is cleaned and oiled as necessary, however more serious concerns, like stripped spindles and threading, are evident. The hardware is original to the time of the house being built and therefore extremely difficult, if impossible, to replace.

The determined solution, although not completed, is to have many of the spindles in the handles of the terrace doors re-tapped and re-drilled with new brass to match the hardware. Additionally, some of the window cranks and door mechanisms may be recast in the same material to serve as replacements.

Continued Maintenance Plan

This paper is always seeking to reinforce the importance of a continued maintenance plan for Usonian homes. They are all at an age where things will begin to happen, and maintenance can serve as a great way to mitigate potential future problems.

The continued maintenance plan at Kentuck Knob includes, in summary, the continued re-pointing of the exterior masonry walls and flagstone floors, the refinishing or re-varnishing of the exterior tidewater red cypress, the cleaning of hardware, as well as yearly maintenance on the boiler system for the heating pipes, and semi-annual checks on the electrical system. These items are only the major portions of continuous efforts to monitor and maintain all aspects of Kentuck Knob.

Case Study House

Home: Rosenbaum House

Location: Florence, Alabama

History

The Rosenbaum's came to Frank Lloyd Wright from a young architect, Aaron Green, in 1939. Green attempted to design a home for his friends, the Rosenblum's, however, the budget was an issue. Green suggested that Wright design them a home much in the same style as he had done for Herbert Jacobs. The Rosenbaum's gave a budget of \$7,500 and Wright began to design with their needs in mind.⁴⁹

The construction was supervised by Burt Goodrich, a very young Taliesin Fellow, who would cut his teeth on this project. As construction was delayed repeatedly, Goodrich ended up staying in Florence longer than either he or Wright had expected. Finally, a beautiful home was completed.⁵⁰

The Rosenbaum home was completed in 1939 on a variant of an L plan, polliwog Usonian home. The home is based on the rectangular module, and therefore focuses on 90-degree angles. The home has three bedrooms and two baths, which was room enough for a growing family.

⁴⁹ Barbara Kimberlin, Broach, Donald E. Lambert, and Milton Bagby, *Frank Lloyd Wright's Rosenbaum House: the birth and rebirth of an American treasure* (San Francisco: Pomegranate, 2006), 19.

⁵⁰ *Ibid*, 21.

The Rosenbaum house is a clear example of an early Usonian home, featuring many common features of the style. The main exterior materials are tidewater red cypress, which could be easily sourced in the home's southern location, and brick. The flooring is concrete with a gravity heating system underneath.

In addition to these common materials and systems, this home exemplifies Wright's organic design philosophies. The flat roofs and overhanging eaves emphasizes its horizontal nature. It appears to be stretched outward in connection with the landscape. The home also has a southern orientation, utilizing the lower winter sun as a sense of passive solar heating.⁵¹

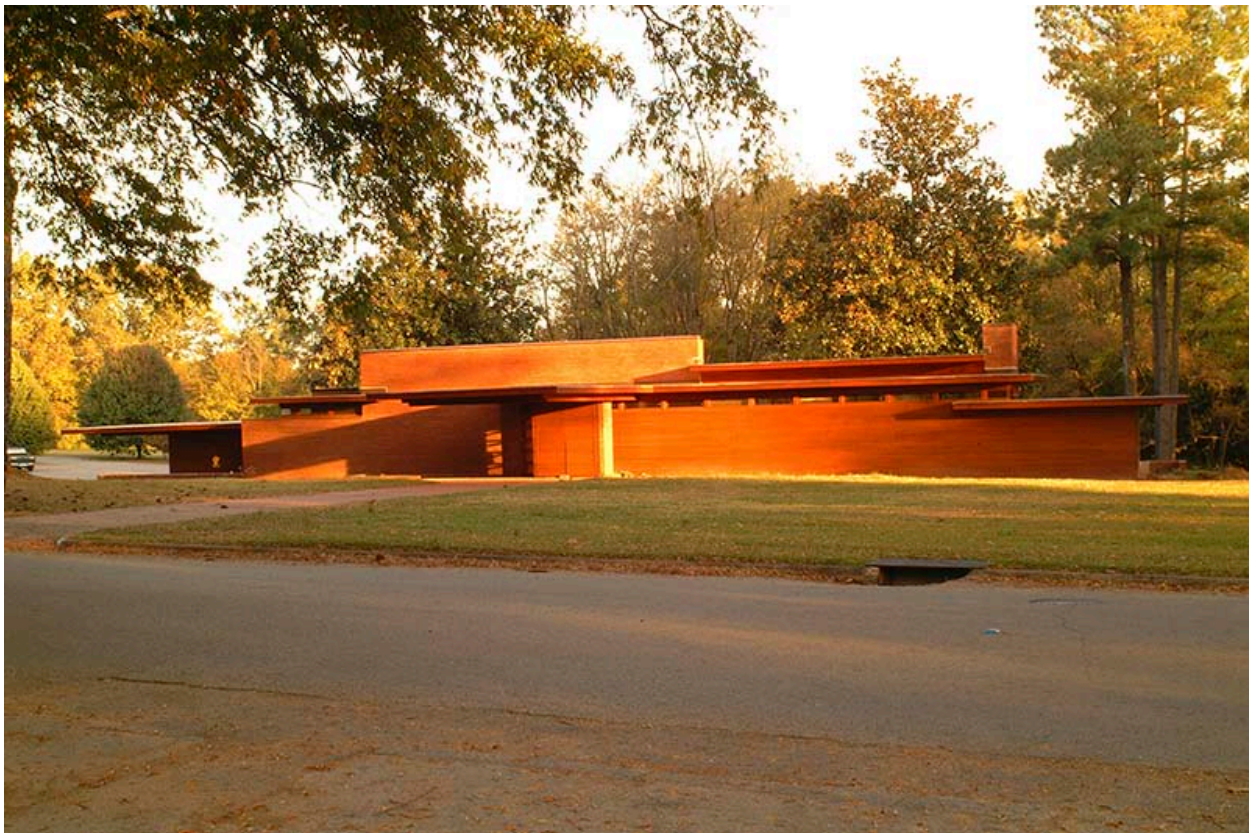

Fig. 7 Street View of Rosenbaum House
Source: *Wrightinalabama.com*

⁵¹Doreen Enrich, *Usonian Houses: Frank Lloyd Wright at a Glance* (London, UK: PRC Publishing, 2002), 42.

Construction, Materials, and Systems

A unique and beautiful feature of Wright's simple and affordable designs was the fact that, oftentimes, the structure of the home was also the finished surface. This places an emphasis on craftsmanship and attention to detail. Due to expressed structural elements, there must be an acute sense of completion and polish in the design. An example of this detail is the mitered corners on exterior and interior wood walls.

The roof of the Rosenbaum house is mostly flat with 3, 2x4s creating the 1/8inch per foot pitch. The original roofing was a tar and gravel system. Originally, three layers of tar paper were put on the roof. The roof was supported by a spider web truss and joist system and, from the beginning, the roof had issues with leaking.

During construction, it was noted that the walls were not properly supported. The poorly supported walls deflected under the weight of the roof and were supported by the addition of fitch plates.

In 1948 an addition was put on the home. The features of this addition were a larger kitchen, a playroom for the children, a guest bedroom, and a laundry room with a separate entrance. The chimneys were reworked in this addition as well as the fireplaces did not work correctly. A major difficulty in this addition was locating cypress during this time.⁵²

⁵² Barbara Kimberlin, Broach, Donald E. Lambert, and Milton Bagby, *Frank Lloyd Wrights Rosenbaum House: the birth and rebirth of an American treasure* (San Francisco: Pomegranate, 2006), 40.



Fig. 8 Rosenbaum House Interior
Source: Wrightinalabama.com

Restoration

The Rosenbaum house, after years of being lived in and loved, eventually fell into disrepair. The home was condemned. It was fortunate then that the City of Florence, Alabama came to purchase the home, understanding its historical significance.

The first step in the restoration process was stabilizing the home. The roof was in terrible condition and water would stream into the house, causing significant water damage. In addition to the water damage, termite damage was also evident. Once the home was stabilized, a new roof was the first course of action.

Roof Replacement

With John Eifler as the consulting architect, the process began. Once the home was stabilized the roof was removed one deck board at a time. The master bedroom roof was resting on 2x4s which had been cut into to add lighting at one point in the home's history. When this portion of the roof was removed, this section of the home fell in.⁵³

The new roof structure consisted of three toenailed 2x4s with steel flitch plates added to prevent deflection. Flitch plates are thin steel plates that are placed in between wood boards to increase strength. They are useful when spanning long distances or to assist in supporting a heavy load. The steel plates are bolted to the lumber and work with the existing support system.⁵⁴

Originally, Wright had specified a 1/8 inch to the foot pitch on the roof, but the home was built with no pitch at all. Shims were used in the restoration process to create the original intended pitch. The material chosen for the new roof was thermoplastic PVC roll roofing by Sarnafil, in a Cherokee red color. During this process, 2-inch polyurethane foam insulation was added as well. The roof was then re-flashed with copper.

The cantilevered carport roof was another issue to be contended with. This roof extends outward 20 feet and was structurally unstable during the time of the restoration. Flitch plates were added to the diagonal roof joists to provide support. In addition to this a steel channel

⁵³ Barbara Kimberlin, Broach, Donald E. Lambert, and Milton Bagby, *Frank Lloyd Wrights Rosenbaum House: the birth and rebirth of an American treasure* (San Francisco: Pomegranate, 2006), 54.

⁵⁴ Jim DeStefano, P.E., *From Experience: Flitch Plate Beams*, PDF, Structure Magazine, June 2007.1.

was added to the inside of the I-beams to counteract flexibility or movement within the cantilever.⁵⁵

Take Away

Roofs are one of the most complex issues to deal with in Wright's Usonian homes, and one of the most prevalent causes for concern and continued maintenance. There are many ways in which a roof can fail, and, in time, most roofs need to be replaced or undergo major repairs.

With the unique roof structure that Wright utilizes in his Usonian designs (and present in this scenario) including deep overhangs, cantilevers, and flat or low-pitch roofs a myriad of structural concerns can arise. This case study introduces a common problem with Usonian roofs – sagging cantilevers. This serious structural issue highlights the importance of understanding the basic construction of these buildings and understanding when to bring in professionals like a restoration architect or structural engineer.

Wood

The Rosenbaum's had originally stained and sealed their Cypress, as many Usonian homeowners decided to do. During the restoration process, it was found that a few boards needed to be replaced. The termites had severely damaged the interior $\frac{3}{4}$ inch by 12-inch sandwich walls, with the primary damage localized near the ground.

⁵⁵ Barbara Kimberlin, Broach, Donald E. Lambert, and Milton Bagby, *Frank Lloyd Wright's Rosenbaum House: the birth and rebirth of an American treasure* (San Francisco: Pomegranate, 2006), 51.

On the exterior, as new wood was replacing the old, it was necessary to sand the entire exterior of the home and refinish all the wood. The Pittsburgh Paints brand Sikkens (discussed later in some detail) worked with the restoration team to come up with a suitable finish for the woodwork. New samples of cypress were sent to the company along with the original woodwork. The company came up with two different types of finish for the wood, as it was determined that the old and new wood absorbed the finish differently.

The exterior finish that was created for the home, the Sikkens finish, had built in Ultra-Violet protection, which is key for these homes; particularly on their more vulnerable southern and eastern sides.⁵⁶The interior woodwork was also refinished in this process. The interior board and batten walls needed to come down to address faulty wiring on the interior of these sandwich walls. New wiring was run in between the walls to bring the home up to code. The board and batten needed to be removed meticulously from top to bottom.⁵⁷

Take Away

The Sikkens brand of wood finish material is one that is widely used in the Wright homeowner community; specifically, when dealing with Redwood, Mahogany, and Cypress.

This project not only introduced to the Wright community a wood finishing product that is now widely used, but also emphasizes the importance of understanding and analyzing how a product can react differently to old growth and new growth wood. It is oftentimes true that old growth and new growth of the same species of wood can have extremely varying properties.

⁵⁶ Barbara Kimberlin, Broach, Donald E. Lambert, and Milton Bagby, *Frank Lloyd Wrights Rosenbaum House: the birth and rebirth of an American treasure* (San Francisco: Pomegranate, 2006), 60.

⁵⁷ Ibid, 55.

It is important to understand how a finish will react to the wood it is used on. This case study can be used as a takeaway for homeowners who have similar or identical materials or problems to the Rosenbaum house. However, it is also important to realize that environmental factors play a role in a products effectiveness such as relative humidity and UV light.

Air Conditioning

C and H Engineers were brought in to discuss how to bring air conditioning into to the home. As it was the desire of the city of Florence to publicly tour the home, it was vital to introduce an air-conditioning system into the home for comfort.

A plenum was introduced to the ceiling of the home in the spaced-out framing system of the ceiling. The empty spaces were insulated with hard foam to support an air handling system. The air compressor was placed outside with a blower located in a closet. As these homes are small and typically do not feature basements a closet was one of the most logical places to place this type of equipment. A package unit was placed on the kitchen roof, concealed behind the parapet walls. The ductwork is run through the ceiling.⁵⁸

Take Away

This serves as the first discussion in this paper on introducing air conditioning into a Usonian home. When they were built, air-conditioning would typically never have been included, however, with this home's hot and humid environment it was vital for touring purposes that the home include this type of system.

⁵⁸ Barbara Kimberlin, Broach, Donald E. Lambert, and Milton Bagby, *Frank Lloyd Wrights Rosenbaum House: the birth and rebirth of an American treasure* (San Francisco: Pomegranate, 2006), 60.

This process speaks to the modern-day reality of comfort needs, especially in a public building in a southern location. The introduction of these new systems requires an understanding of sensitive installation methodologies, effects of increased moisture, as well as proper ventilation techniques, among others. These issues will be discussed in detail in a future section.

Case Study Home

Home: Pope-Leighey House

Location: Alexandria, VA

History

The Pope-Leighey home was designed for Loren Pope, who was a Copy Editor for the Evening Star, a newspaper out of Washington D.C.. Mr. Pope wanted a Jacobs' style home and wrote to Mr. Wright, flattering him into agreeing to design a home for him and his wife. Wright agreed to design for the young couple and construction began in July of 1940. After a short construction period, the Pope's moved in in March of 1941.

The budget for the home was a modest \$5,500. The Pope's accepted Wright's design and asked only for a spot for books and a terrace. The Pope's lived in the home only for a short while. Loren received a new job, which meant a need to move away from their town of Falls Church, Virginia. The home was then purchased by Robert and Marjorie Leighey in 1947. The couple lived in the home happily for many years until development threatened its demolition. In 1963 a highway project was approved in the town of Falls Church which would cut right through the property. When the highway plan was finalized, after a fight to change it, it was then clear that the only way to save the home was to move it.

On July 30th 1963, the house ownership changed hands from the Leighey family to the National Trust for Historic Preservation, who have maintained the home since this date. The chosen site was that of Woodlawn, formerly a part of George Washington's Mount Vernon,

only thirteen miles from the home's original site. The location was chosen for its striking similarity to the original siting chosen by Wright, however, it did not prove to be the most stable. In the late 1980s and 1990s the site underwent a series of structural analyses and tests as issues were arising in the home.

The concrete flooring was cracking significantly, and the roof was leaking. It was found that the clay soil where the house sat was unstable and the roof drainage systems were improperly installed during the movement of the home. When this issue was discovered, it was decided that the house would need to be moved, again, 30 feet "upslope" from its current location. And so, the home was meticulously deconstructed again and reconstructed.⁵⁹

Construction, Materials, and Systems

The Pope-Leighey house is constructed of brick and tidewater red cypress with colored concrete floors on top of a radiant heating system. The cypress siding features the classic Usonian board and recessed batten.

The home's orientation is toward the South with clerestory windows, large swaths of glazing, and overhanging eaves and a carport.⁶⁰ Based on the "L" shaped plan, the home features modest sized spaces, which appear larger with differing ceiling heights and light infiltration.

Restoration

⁵⁹ Lauren Walser, "Pope-Leighey House Prepares for Frank Lloyd Wright's 150th Birthday," SavingPlaces, , accessed November 13, 2017, <https://savingplaces.org/stories/pope-leighey-house-prepares-for-frank-lloyd-wrights-150th-birthday>

⁶⁰ Doreen Enrich, *Usonian Houses: Frank Lloyd Wright at a Glance* (London, UK: PRC Publishing, 2002), 48.

Movement and New Material

The home was meticulously taken apart and moved on a flatbed truck to its first new location. The wood, structural elements, and systems were able to be saved, however, the brick could not be removed successfully without severe damage and the concrete slab floor had to be sacrificed as well. These were building elements that were replaced during the movement process. This gave the home the benefit of receiving a new radiant heating system, new flooring, and brickwork every 20 odd years. What remained was the wood, which will be discussed in the next section.

Take Away

While moving a home should always be a last and final effort to save a home, as it removes the home from its original and intended context, sometimes it is necessary and does have some benefits. Those benefits include the ability to address any issues in the home that are material or systems based. If you are able to save the main structure of the home and many of the original character defining features, then the ability to redo some aspects of the home can be good for the health of the home.

Wood Preservation

The cypress that makes up most of the exterior and interior surface of the home is primarily original, despite the movements of the home. With the wood being original there were, of course, issues that developed over time. One issue was raised grain on the wood, which could be evidence of previous pressure washing treatments.

Because some of the wood was original and some was new replacement wood it was necessary to find a finish, or combination of finishes, that would work well with each wood age. Two conservators teamed up with University of Pennsylvania to investigate how to treat or refinish the woodwork on the home.

Ten products were tested in total with longevity, saturation, and historical accuracy in mind. In the meantime, Oak Grove Restoration placed Dutchman repairs in the cracks of the cypress siding to stabilize the siding. Eventually, a solution was determined to clean and preserve the tidewater red cypress siding.

First, D/2 Biological Solution was used to clean the wood. Once the wood was clean Bora-Care was applied as a biological deterrent which also served to deter termites, carpenter ants, and other wood eating pests. The final step was the protective coating. TWP 1530 was suggested as the finish coat as it is water repellent, UV protectant, and aids in color retention for the reddish tint to the wood at risk of turning greyish-black.⁶¹

This system of cleaning and finishing the wood was applied during the restoration process in 2015 and has been successful for the home. This is a system that could be replicated for other Usonian homes that have cypress as their wood.

Take Away

The take away for this wood restoration is that timing is everything for the success of this type of project. With this type of multi-step system, it is important to follow all application

⁶¹ Lauren Walser, "Pope-Leighey House Prepares for Frank Lloyd Wright's 150th Birthday," SavingPlaces, 45, accessed November 13, 2017, <https://savingplaces.org/stories/pope-leighey-house-prepares-for-frank-lloyd-wrights-150th-birthday>

instructions. It was imperative that the finish material be applied between the temperatures of 50 and 90 degrees, which provides a window in which it is feasible to carry out the project. Also, the relative moisture content of the wood needed to be below 11%, which necessitated sufficient initial dry-time, as well as drying in between treatments to ensure that the coatings would set properly. It is imperative to follow all instructions when applying this type of finish on wood. If too much moisture is present, or the temperature is too extreme, the finish could immediately fail, making it necessary to remove the finish and begin again.

Chapter 4

Homeowners and Public Sites Survey

The results from Homeowner and Public Sites Survey provided the bulk of the data that will be analyzed in the following sections of this paper. The survey data is a vital resource as the information is coming directly from the stewards who are living with and addressing these concerns on a daily basis. Collecting first hand experiences and knowledge is the first step in producing a resource by and for the people who care for these homes.

The Usonian model of home features a truly unique style, use of material, and method of construction as compared to Wright's of bodies of work. The Usonian model was an evolution and not a static form, and as such this paper takes a broad understanding of what can be labeled as "Usonian". Some homes included in this survey may fall outside of conventional use of this nomenclature, however, they are still representative of the materials, methodologies, and issues that were and are present in these homes.

The Usonian model was chosen specifically due to their unique construction techniques and the issues that arise with the then modern building technologies and their ability to stand the test of time. The survey, and other first-hand sources, make-up the basis for understanding the particular concerns with these types of homes. It is the goal of this survey and paper to collect, analyze, and synthesize the experiences of the Usonian homeowners and provide a usable resource based on their experiences, additional research, and recommendations from professionals in the field.

The survey was formatted to capture specific information from recipients that can be broken down into six categories. The first is general and gathers basic information about the home, its location, and time of ownership. Most of the results from this section are not included in this paper aside from general knowledge regarding age of building, geographic area and its climatic and material make-up effects on a building, and general existing condition.

The second category is structural, which gathers information about current materials and building systems. An understanding of envelope and interior materials, foundation, roof line and pitch, and other structural materials and pathologies is key to identifying patterns of issue or maintenance based on these parameters.

The third, and most crucial, addresses everyday maintenance concerns and practices. This section asks stewards to list their most common preservation issues as well as to identify their top continual maintenance activities. This information, when discussed in relation to the other factors of the building and site, provides for the basis from which the analysis and identification of patterns can be created. While the survey takers were given a set of answers to choose from when identifying common problems, there was also a field to add in their own comments. The question on top maintenance priorities and activities was entirely at the discretion of the survey taker, which provided a unique forum for candid answers.

The next section on rehabilitation seeks to understand large-scale, one-time projects. Over time, many homes will have issues that need to be resolved as building elements fail. Sometimes, these are one-time fixes in the span of ownership. This information is important to

understand and differentiate from the recurring issues in a home that require cyclical maintenance.

The purpose and use of this survey extends beyond this paper and will be utilized by the Frank Lloyd Wright Building Conservancy, who provides technical preservation resources for Wright properties. This information will be used to determine common problems, as well as begin to identify solutions to these problems. The following sections attempt to ensure continued preservation of these homes through education and other forms of protection. The section, Preservation Education, was created to determine how homeowners would like to receive, if any, practical preservation information and resources. The final section, Continued Protection, seeks to identify those owners who may be interested in a preservation easement on their home or who may be protected under local historical organizations or ordinances.

The Homeowners and Public Sites Survey was created in conjunction with and distributed by the Frank Lloyd Wright Building Conservancy. The Conservancy's mission is to preserve and protect all of Wright's extant work. They are the premier organization for practical resources for owners of Wright's homes. As such, this thesis topic is of great interest for them.

The survey was sent out to 109 recipients who currently own, have previously owned, or steward a Frank Lloyd Wright Usonian home. The 62 responses that came back assist in the understanding of the most common preservation issues within Usonian homes.

The results of this survey are broken down in the next section of this paper.

Survey Results

Structural

Most Common Exterior Material

The graph identifies the actual number of individual survey responses (some answers are not shown as they represent an insignificant percentage or are “write-in” answers identical to existing and have been enveloped into that category):

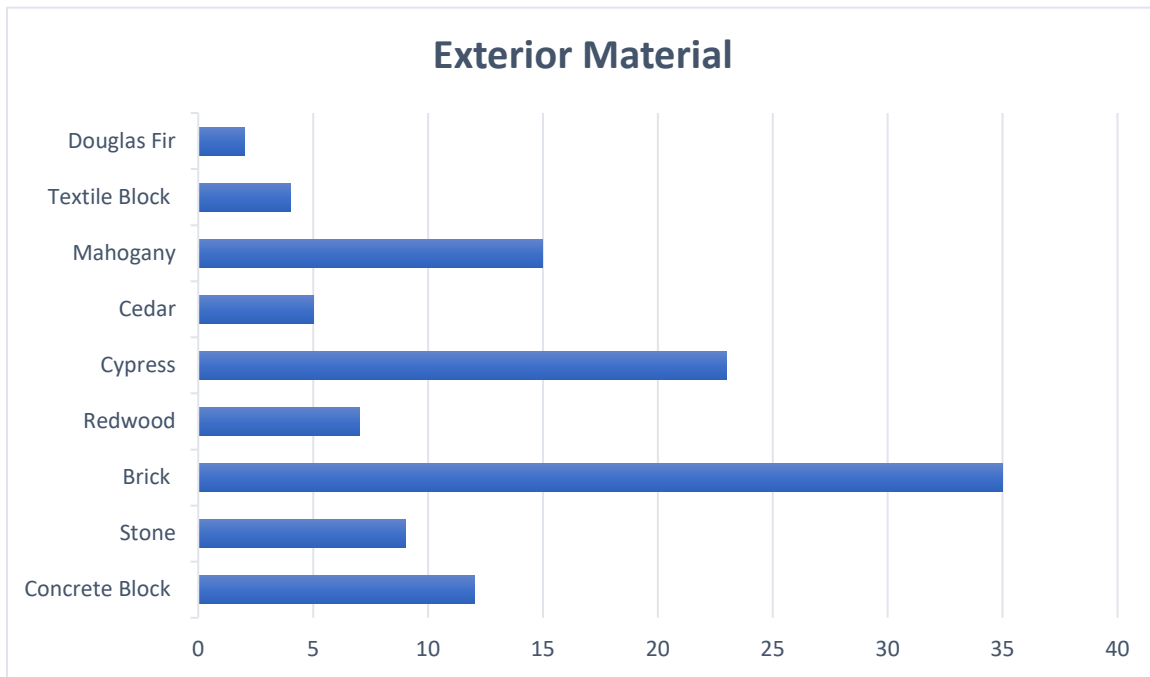

The below information indicates the percentage of respondents (some answers are not shown):

Concrete Block – 20.3%

Stone - 15.3%

Brick – 59.3%

Redwood – 11.9%

Cypress – 39%

Cedar – 8.5%

Mahogany – 25.4%

Textile Block – 6.8%

Douglas Fir – 3.4

Most Common Interior Materials

The graph identifies the actual number of individual survey responses (some answers are not shown):

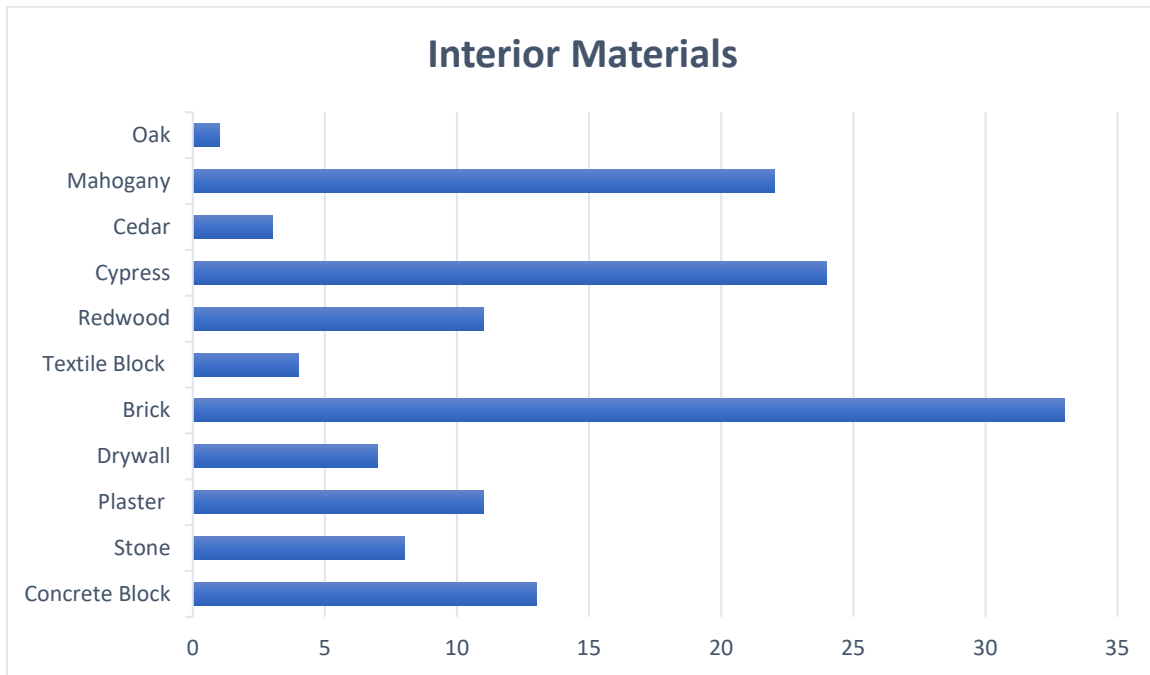

The below information indicates the percentage of respondents (some answers are not shown):

Concrete Block 22%
Stone 13.6%
Plaster 18.6%
Drywall 11.9%
Redwood 18.6%
Cypress 40.7%
Cedar 5.1%
Mahogany 37.3%
Brick 55.9%
Glass 3.4%
Textile Block 6.8%
Oak 1.7%

Roofing

The graph identifies the actual number of individual survey responses (some answers are not shown):

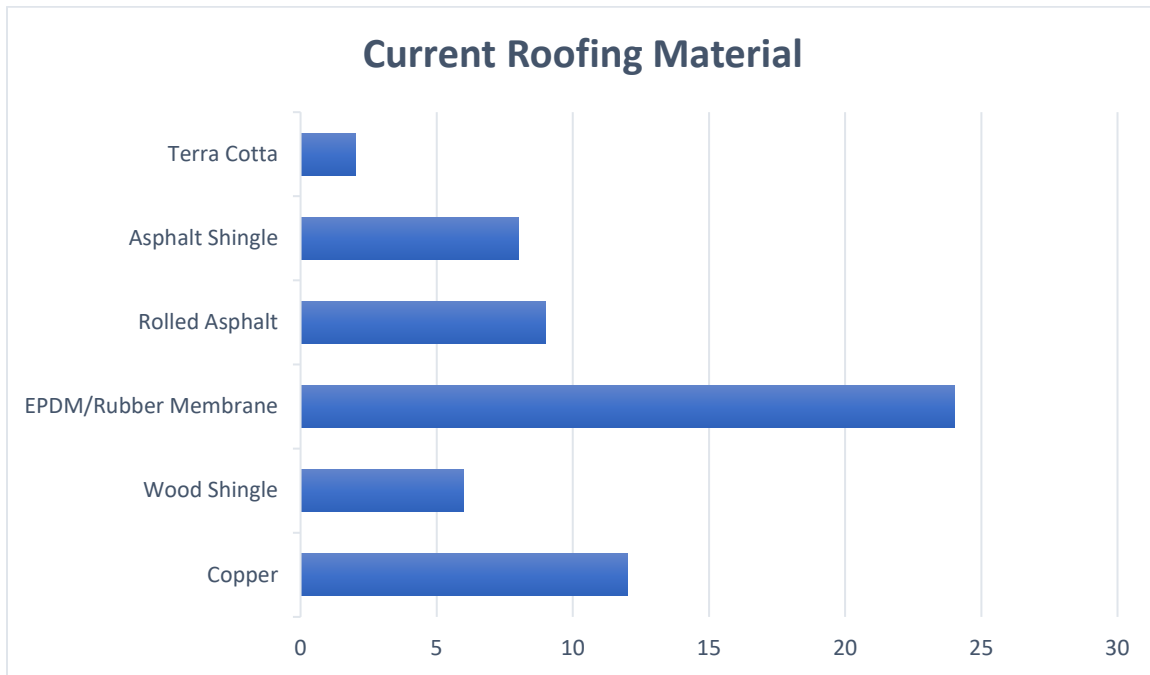

The below information indicates the percentage of respondents (some answers are not shown):

Copper 21.1%
Wood Shingle 10.5%
EPDM/Rubber Membrane 42.1%
Rolled Asphalt 15.8%
Shingle Asphalt 14%
Terra Cotta 3.5%
PVC Membrane 1.8%
Acrymax Acrylic Membrane 1.8%
Dex-O-Tex Built Up Roofing 1.8%

Most Common Roof Form

The graph identifies the actual number of individual survey responses (some answers are not shown):

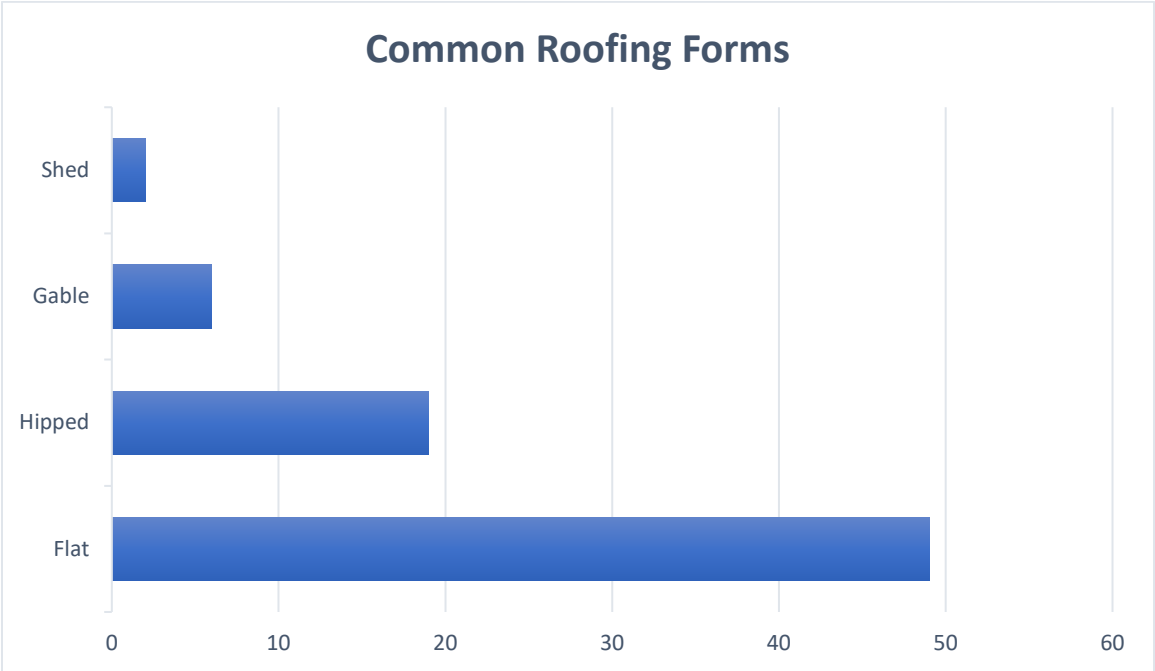

The below information indicates the percentage of respondents (some answers are not shown):

- Flat 86%
- Hipped 33.3%
- Gable 10.5%
- Shed 3.5%

Flooring Materials

The graph identifies the actual number of individual survey responses (some answers are not shown):

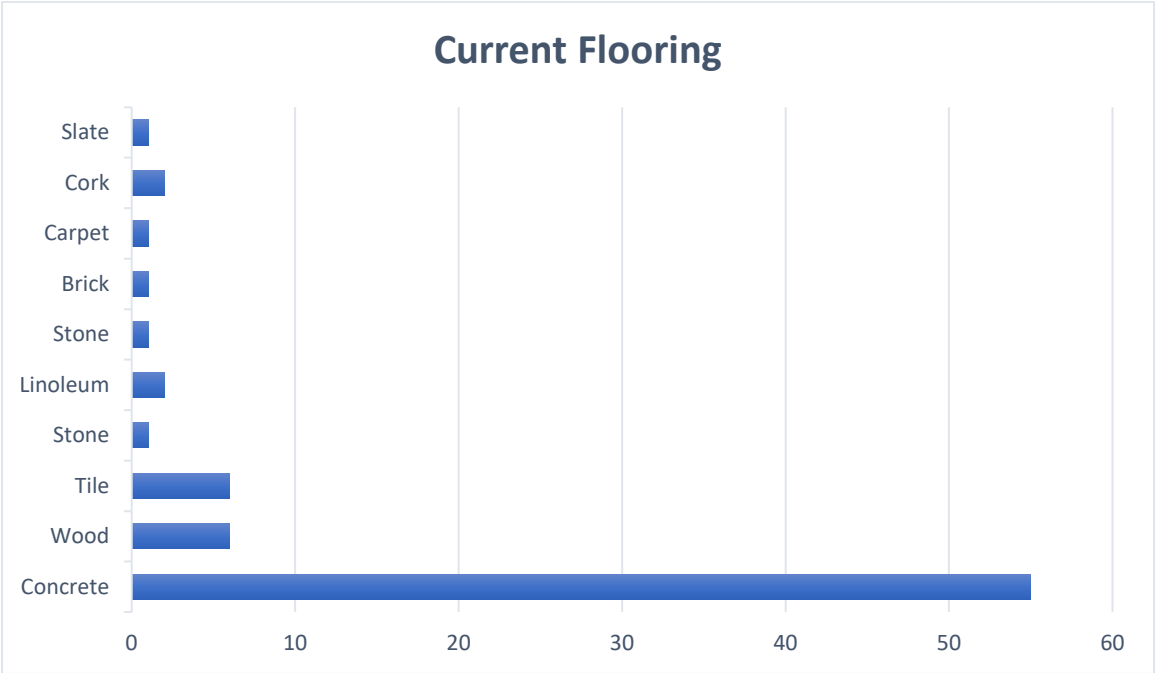

The below information indicates the percentage of respondents (some answers are not shown):

- Concrete 93.2%
- Wood 10.2%
- Tile 10.2%
- Linoleum 3.4%
- Stone 1.7%
- Carpet 1.7%
- Brick 1.7%

Most Common Heating Systems

The graph identifies the actual number of individual survey responses (some answers are not shown):

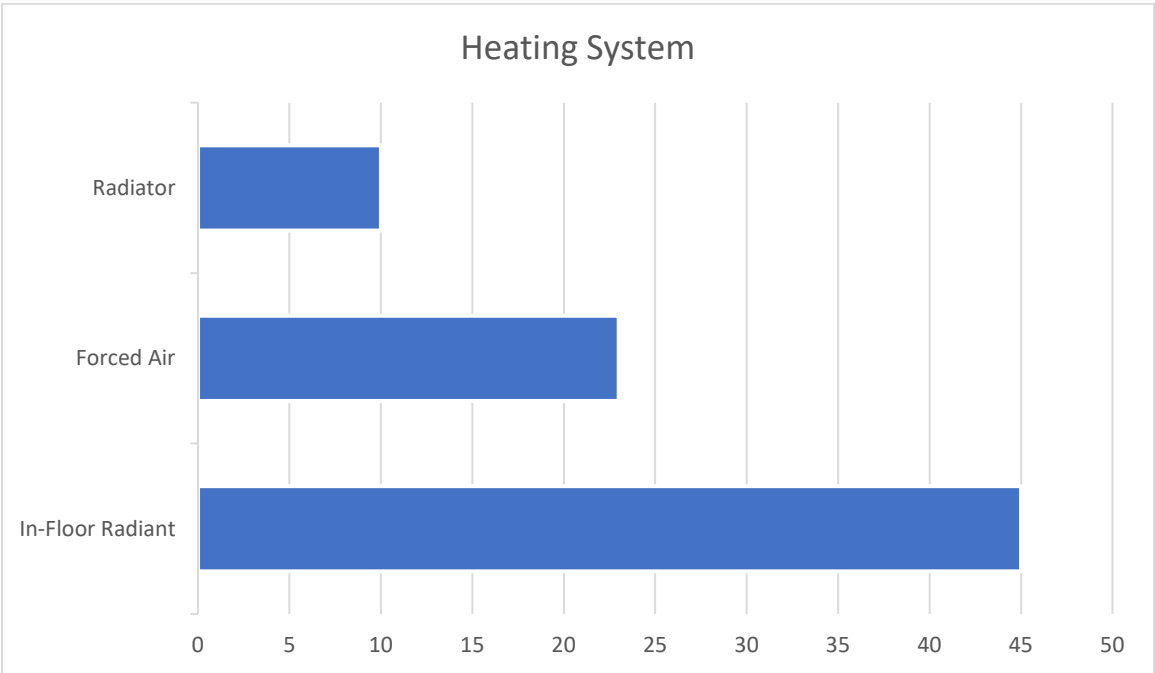

The below information indicates the percentage of respondents (some answers are not shown):

- In-floor Hydronic Radiant Heat 76.3%
- Forced Air 39%
- Radiator 16.9%

Most Common Window Type

The graph identifies the actual number of individual survey responses (some answers are not shown):

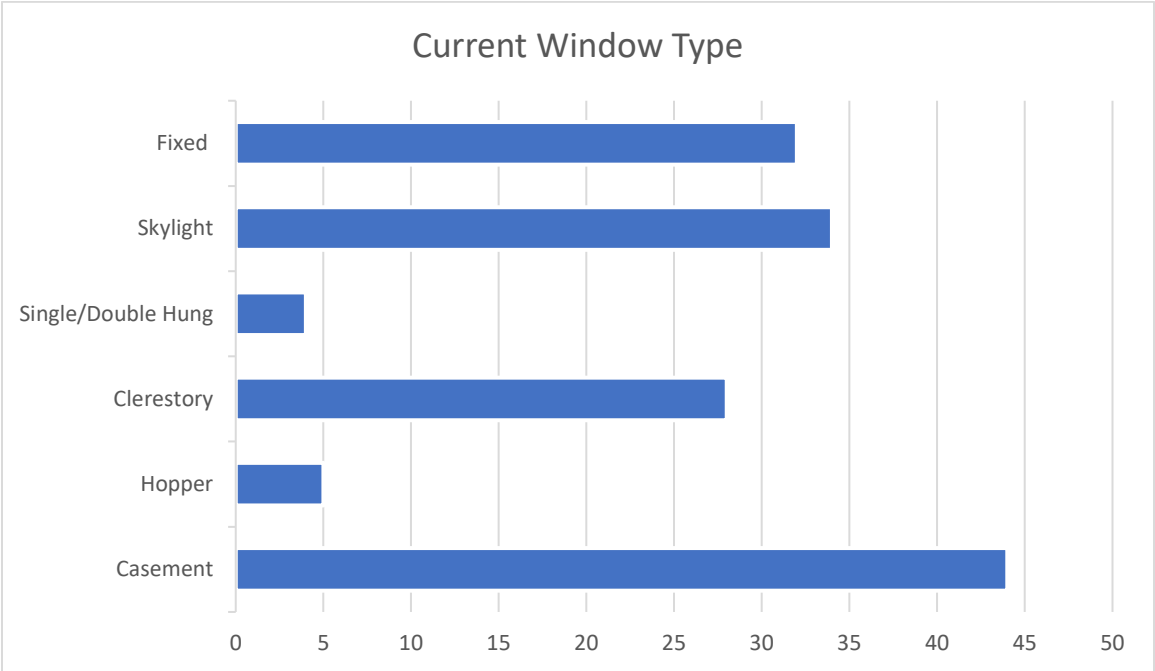

The below information indicates the percentage of respondents (some answers are not shown):

- Casement 74.6%
- Single/Double 6.8%
- Hopper 8.5%
- Clerestory 47.5%
- Skylight 57.6%
- Fixed 54.2%

Most Common Glazing

The graph identifies the actual number of individual survey responses (some answers are not shown):

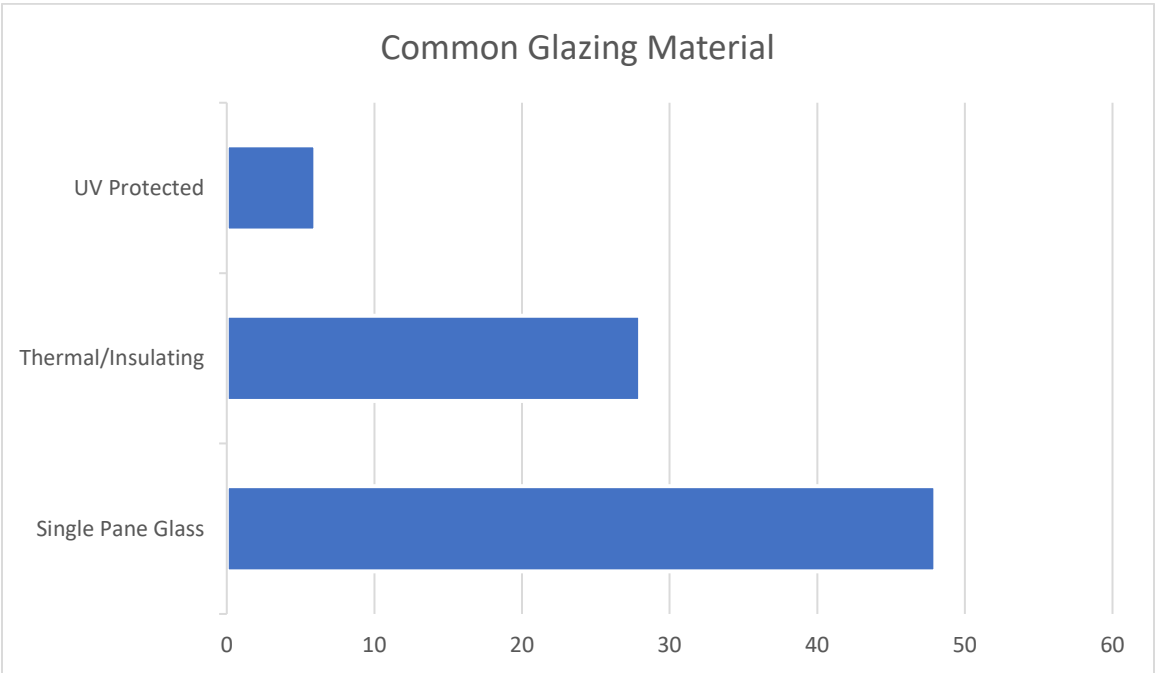

The below information indicates the percentage of respondents (some answers are not shown):

- Single Pane Glass 82.8%
- Thermal/Insulating Glass 48.3%
- UV Protected Glass 10.3%

Maintenance

When asked what general condition the home was in when purchased the following were the responses:

The graph identifies the actual number of individual survey responses (some answers are not shown):

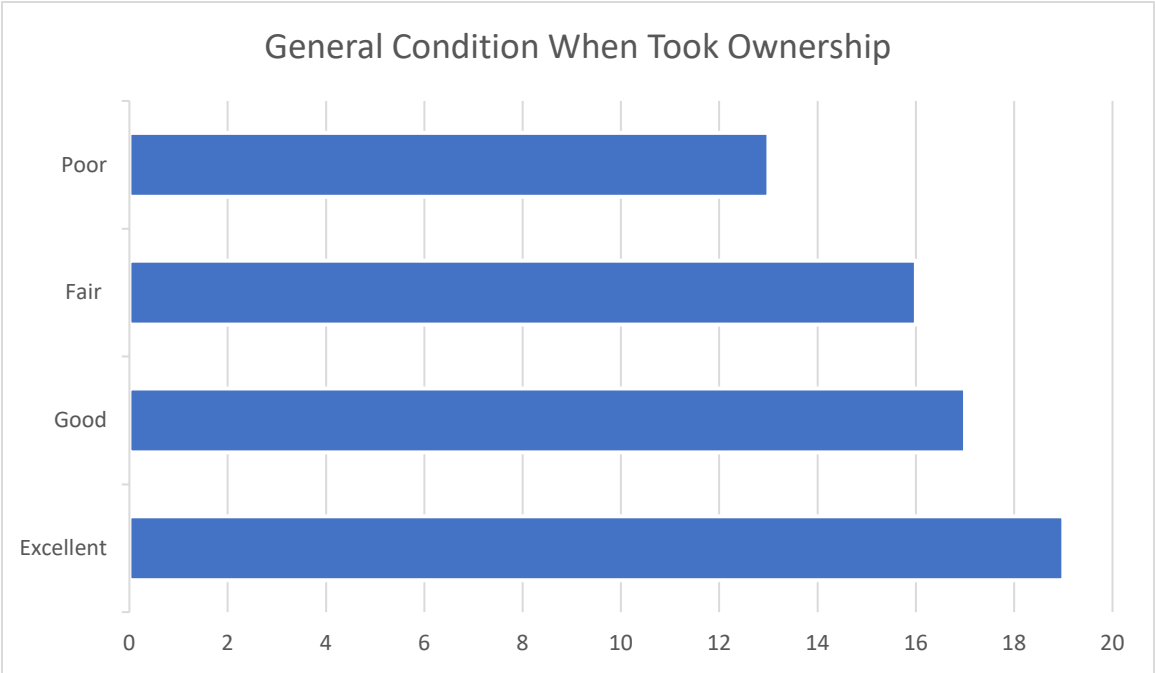

The below information indicates the percentage of respondents (some answers are not shown):

- Excellent 19%
- Good 29.3%
- Fair 27.6%
- Poor 22.4%

The recipients of the survey were asked to choose from a list of common preservation issues in Usonian homes to determine whether they had dealt with these issues in the past. There was also a section to write in their own responses to capture as much information about the issues facing Usonian homes as possible.

Below is a list of answers to this inquiry:

The graph identifies the actual number of individual survey responses (some answers are not shown):

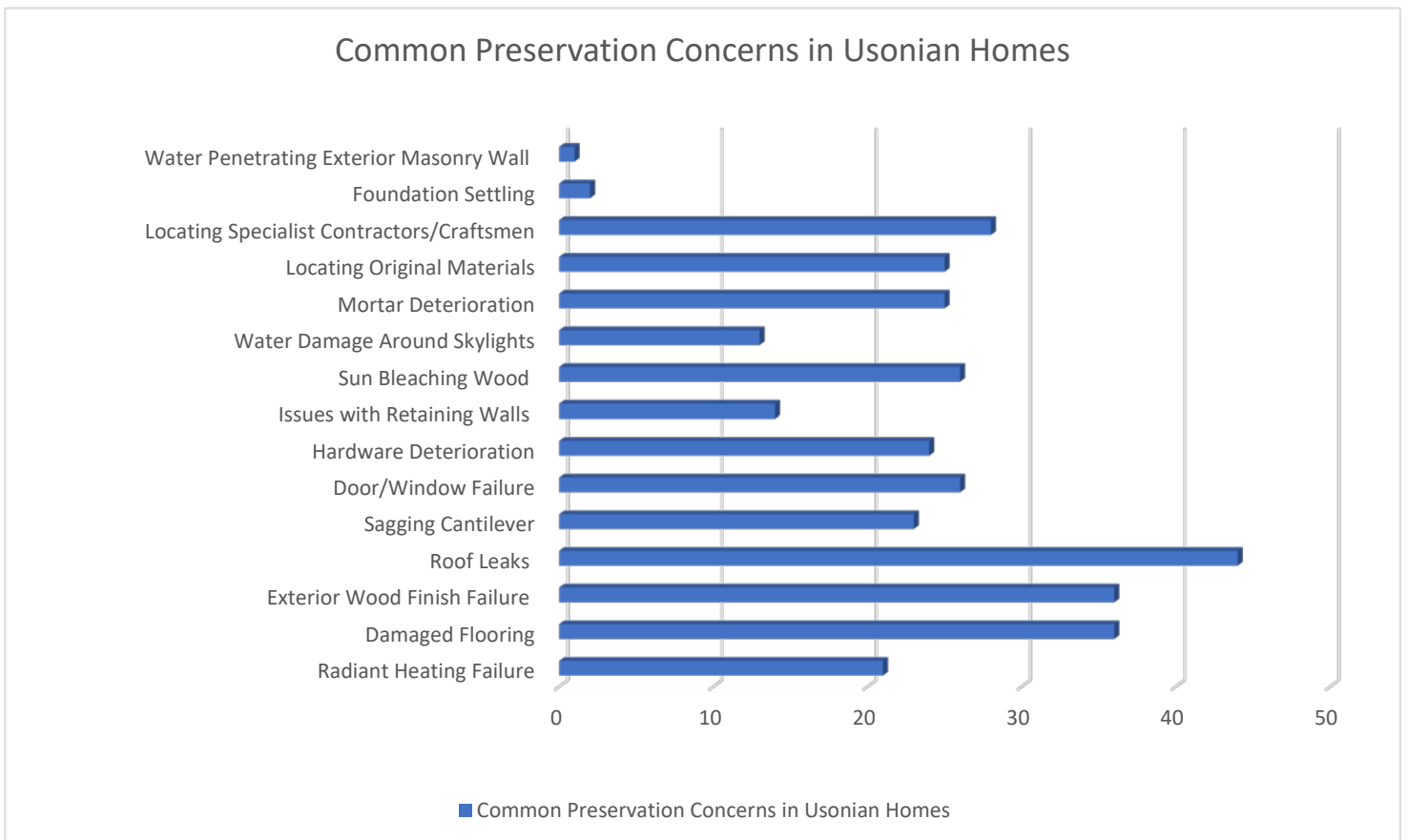

The below information indicates the percentage of respondents (some answers are not shown):

Radiant Heating System Failure 35%
Cracked or Damaged Flooring 60%
Wood Treatment/Finish Failure 60%
Hardware Failure 40%
Door and Window Failure 43.3%
Sagging/Failing Cantilever Roof Structure 38.3%
Leaks in Roof 73.3%
Failure of Retaining Walls 23.3%
Sun Bleaching of Woodwork 43.3%
Locating Original Materials for Restoration Projects 41.7%
Locating Specialist Contractors/Craftsmen 48.3%
Water Intrusion and Damage via Skylights 21.7%
Mortar Deterioration 41.7%
Textile Block Deterioration 1.7%

Survey takers were asked to list their top five maintenance priorities on their home. The ten most common are listed below in no particular order.

Pruning foliage around house and other general landscaping
Roof maintenance which includes removing debris or fixing leaks, etc
Exterior wood finish reapplication
Monitor and maintain radiant floor equipment (boiler, pipes, etc)
Seal exterior masonry with a water repellent or proofing material
Tuck pointing
Window cleaning
Checking for water intrusion of any kind from foundation to roof
Maintaining or fixing concrete flooring (Color, cracks, etc)
Work on windows, doors, and hardware

Rehabilitation and Renovation

When asked if their homes had undergone any of the following major rehabilitations or major system replacements during their ownership they answered:

The graph identifies the actual number of individual of survey responses (some answers are not shown):

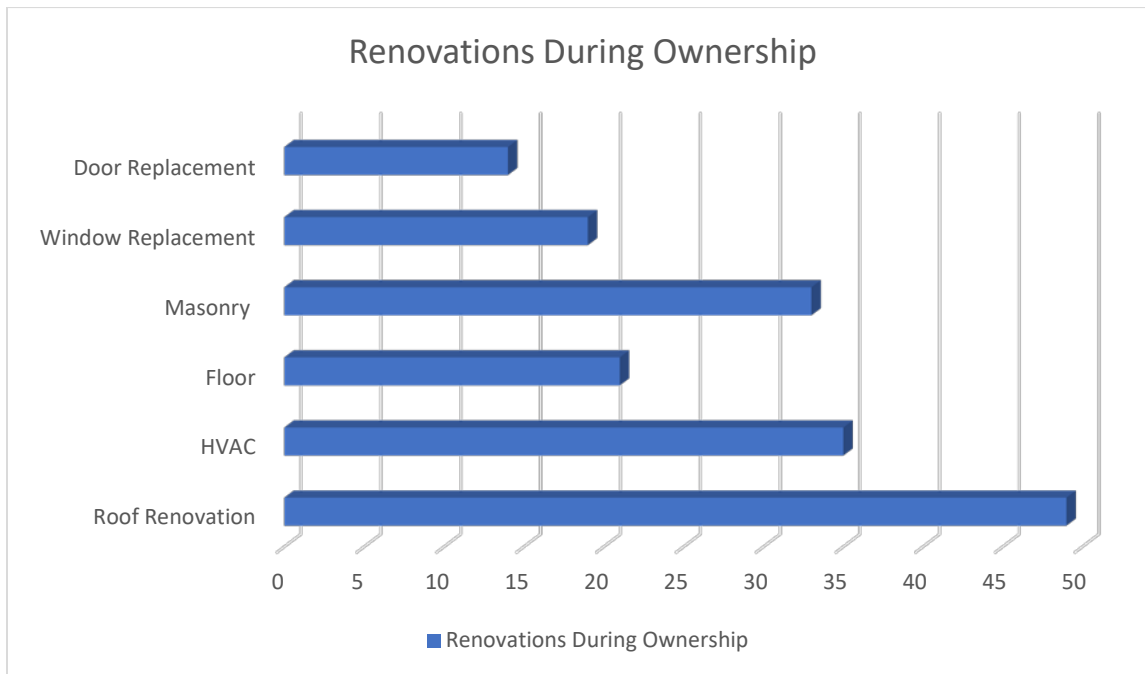

The below information indicates the percentage of respondents (some answers are not shown):

Roof Rehabilitation/Replacement 84.5%

HVAC 60.3%

Flooring 36.2%

Masonry 56.9%

Window Replacement 32.8%

Door Replacement 24.1%

Most Commonly Identified Resources

The graph identifies the actual number of individual of survey responses (some answers are not shown):

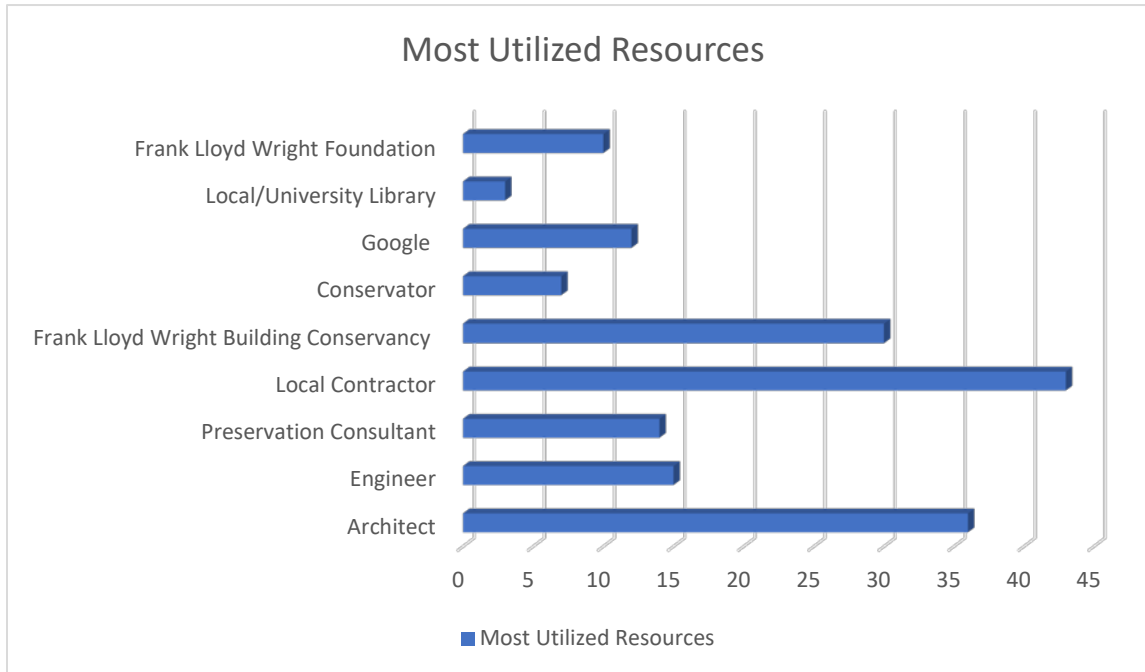

The below information indicates the percentage of respondents (some answers are not shown):

- Architect 61%
- Engineer 25.4%
- Historic Preservation Consultant 23.7%
- Conservator 11.9%
- Local Contractor 72.9%
- Frank Lloyd Wright Building Conservancy 50.8%
- Frank Lloyd Wright Foundation 16.9%
- Google 20.3%
- Local/University Library 6.8%

An Analysis of the Results

The main purpose of this survey was to identify common preservation and maintenance concerns within these homes. The best way to collect this information is to ask those who deal with them daily. Homeowners and site managers are the main forces behind saving these homes. By collecting their knowledge, along with professionals in the field, a comprehensive resource can be created to assist in delivering information about these common issues and ways to mitigate them.

The above data collected on maintenance priorities, ongoing issues, major rehabilitations, and the like combine to identify the top maintenance and preservation issues that are found in Frank Lloyd Wright's Usonian homes. These items will be discussed in detail in the following section.

Identification and Analysis of Common Issues

First, it is important to note that every home is different, and every issue is unique. These resources and case studies are included in this paper to serve as sources of information and potential guidelines for homeowners dealing with similar issues. All restoration projects should be thought of as unique and, when necessary, should be under the supervision of a professional in that specific field.

Failure of In-Floor Radiant Heating Systems

Prevalence of Issue

Radiant or gravity heat that is embedded in the floor was nearly a standard feature in Frank Lloyd Wright's Usonian homes. He began early with his first Usonian homes, Jacobs I. As such, in addition to this being a common system in these homes it is also a common maintenance issue for them.

Of those surveyed, 38.2% of the respondents stated that radiant heating failure was one of their most prevalent maintenance issues. In addition to this, 56.6% of respondents answered that their HVAC system had undergone major repair or replacement before or during their ownership.⁶²

Common Causes of Issue

This concern is among the most prevalent because of the nature of the system. As with all systems, there are inherent problems and natural degradations. These in-floor radiant heat systems have their own specific set of problems caused by the material used during these early years in radiant flooring technology.

Typically, when these homes were being constructed the radiant heated pipes were made of either copper, steel, or cast iron. There are many ways in which these systems fail, and it is important to first understand how they are implemented into a home.

⁶²"Usonian Homeowners and Public Sites Survey," e-mail interview by author, September 2017

There are three main types of in-floor radiant heating. The first, and by far the most common, is a hydronic system which flows hot water through the piping heated by a boiler. In this system, the temperature is controlled by regulating the flow of water. Often these systems are in two to three major zones, which feature their own pumps and valves to control temperature within the zones. The second system, which is very rare, is a radiant air system. This type holds significantly less heat in large areas and is less desirable, as it is less cost effective and efficient.⁶³ The third type is an electric based system, also relatively uncommon.

In the first system, the tubes, originally made of the metals mentioned above, were typically installed one of two ways in these homes. The first is referred to as a dry installation, where the tubing is sandwiched between the subfloor and the finish floor material. A wet installation is when the tubing is embedded directly into the concrete floor or sub-floor. This type of system uses the thermal mass of the concrete to conduct and transfer heat.⁶⁴

The early copper tubing elements were typically 5/8 inch in width. A major cause of failure in these early copper, steel, or iron systems was the reaction of the ferrous metal components with the concrete.⁶⁵ The reaction between the metal and concrete caused corrosion of the tubing, making it susceptible to failure. Additionally, water quality and chemical make-up is a concern. Certain trace elements in the water could react negatively with

⁶³ "Radiant Heating Systems - Floors," Penn State University , accessed November 12, 2017, <https://www.e-education.psu.edu/egee102/node/2111>

⁶⁴ Ibid

⁶⁵ Roger Dodge Woodson, *Radiant floor heating* (New York: McGraw-Hill, 2010), 30, accessed November 12, 2017, http://web.b.ebscohost.com.libproxy.tulane.edu:2048/ehost/ebookviewer/ebook/bmxlYmtfXzl5MTQ1M19fQU41?sid=36dcf75f-986e-45b2-9263-5b52adee1d29@sessionmgr103&vid=0&format=EB&lpid=lp_29&rid=0.

the metal and cause corrosion. This can create holes or cracks in the system, causing a major failure.⁶⁶

Original installation methodology is also a cause of failure. At times, the metal piping would be laid without proper support and, with too much “play”, the pipes will fail.⁶⁷ In testament to this, it was specified that additional supports would be needed to secure the iron piping to the rebar when the radiant heat was installed at Kentuck Knob.

Another problem with these systems is the potential for significant differences in temperature between the pipe zones. One homeowner described an issue with thermal expansion due these differences which caused the lines to crack.⁶⁸

Along this same line is the potentially damaging effects of cold weather. If water is left in the tubing in the winter with no active heating the water could freeze and cause pipe damage, much like with plumbing. This problem, however, is easily mitigated with continued monitoring and care of the system in the winter months. If the house is not occupied regularly during winter months the heat should either be set at a continual minimal temperature to avoid freezing, or the system can be winterized by draining the water from the pipes.

With modern materials and installation methodologies, replacement systems are typically not susceptible to these concerns. However, when these pipes crack or leak it is a

⁶⁶ "Radiant Heating Systems - Floors," Penn State University, accessed November 12, 2017, <https://www.e-education.psu.edu/egee102/node/2111>

⁶⁷ Roger Dodge Woodson, *Radiant floor heating* (New York: McGraw-Hill, 2010), 30, accessed November 12, 2017, http://web.b.ebscohost.com.libproxy.tulane.edu:2048/ehost/ebookviewer/ebook/bmxlymtfXzI5MTQ1M19fQU41?sid=36dcf75f-986e-45b2-9263-5b52adee1d29@sessionmgr103&vid=0&format=EB&lpid=lp_29&rid=0.

⁶⁸ "Usonian Homeowners and Public Sites Survey," e-mail interview by author, September 2017

major undertaking to resolve the issue due to their placement under or within the floor. Often, it is necessary to remove the flooring partially or completely to repair or replace these systems.

A Note on Freezing Pipes

It is a common belief that pipes burst or are damaged during cold snaps due to the water in the pipes freezing, expanding, and bursting the pipe. The actual damage to the pipe is caused by increased water pressure, which causes plastic deformation in the pipe – weakening it. As the pipe is exposed to freezing temperatures the ice forms first around the wall of the pipe acting, at first, as an insulator. Eventually, this ice grows and begins to block the water flow. When this happens close to the house and fixtures, the water pressure rises and damages or bursts the pipe.⁶⁹

A metal pipe will fail at its weakest point as it is only so elastic. The introduction of PEX tubing, which allows for 8% volume change, will assist in preventing this type of damage. This is true in both plumbing and hydronic heating systems.⁷⁰

Benefits of Radiant Heating System

There are many advantages of utilizing this type of system. Wright popularized this system and appreciated that it gave his clients warm feet and a cool head! Below are some of the other benefits of in-floor radiant heat. These, in conjunction with the importance of maintaining the integrity of the original design, make the case for replacing in-kind or repairing

⁶⁹William B. Rose, *Water in Buildings: An Architects Guide to Moisture and Mold* (Hoboken, NJ: John Wiley & Sons, 2005), 229

⁷⁰William B. Rose, *Water in Buildings: An Architects Guide to Moisture and Mold* (Hoboken, NJ: John Wiley & Sons, 2005), 230

the original system in a Usonian home. However, it is also prudent to use modern materials in these repairs or replacements.

Some of the many benefits include:

- Even heating throughout home
- Warms the body first through direct contact with floor
- Elimination of dust and allergen concerns
- Aesthetically pleasing; no visible registers or radiators
- Uses thermal mass to maintain temperature longer⁷¹

Recommendations for Repair/Replacement

Today, radiant heat is a more popular choice for a heating solution. Arguably, this system is more efficient than its electric baseboard or forced-air counterparts, making it a smart choice to replace the original system with modern materials that perform in the same manner.

It is imperative to locate a qualified contractor to repair or replace an original radiant heating system. The intricacies of proper installation are important to understand prior to beginning a replacement or repair project. A few of the most important considerations are thickness of concrete and an analysis of the heat loss per square foot, desirable average surface temperature, R-value of the finished floor materials, rate of water flow through piping, and the tubing spacing, size, and length, and the inclusion of an oxygen diffusion barrier in the tubing. An understanding of the substrate and finish material and their R-value is vital in determining the proper size of the system and its efficiency for the room or home.⁷²

⁷¹ "Radiant Heating Systems - Floors," Penn State University, accessed November 12, 2017, <https://www.e-education.psu.edu/egee102/node/2111>

⁷² "Radiant Heating," Department of Energy, accessed November 12, 2017, <https://www.energy.gov/energysaver/radiant-heating>.

Replacement: PEX Tubing

Today the standard material is Pex tubing, which is a cross-linked polyethylene material. Pex has many applications, including in modern plumbing. This tubing is inherently flexible, which allows for natural expansion and contraction with changes in the temperature. Even though the tubing will naturally bend, it is important not to hyper-extend the tubing which can cause water flow restriction.⁷³

The tubes are usually set up in a loop, which are each approximately 200 feet in length. If a metal tubing material is being used (in some instances copper is used in modern applications), then an oxygen diffusion barrier is needed in the tubing to prevent oxidation and corrosion.⁷⁴ Today, these types of systems can also be implemented in ceilings or walls if it is not feasible or economical to replace or repair the existing in-floor radiant heating system.

Homeowner Advice:

One homeowner mentioned having great success with the use of Pex tubing in their new radiant heating system, however, cautioned to ensure an even depth of the tubing installation, as to ensure even temperature throughout.⁷⁵

Low Profile Pre-Fab Panels

⁷³ PexUniverse www.pexuniverse.com, "PEX Tubing Technical Specifications and General Installation Recommendations," PEX tubing technical specifications and general installation practices, , accessed November 12, 2017, <https://www.pexuniverse.com/pex-tubing-technical-specs>.

⁷⁴ Roger Dodge Woodson, *Radiant floor heating* (New York: McGraw-Hill, 2010), 30, accessed November 12, 2017, http://web.b.ebscohost.com.libproxy.tulane.edu:2048/ehost/ebookviewer/ebook/bmxlYmtfXzI5MTQ1M19fQU41?sid=36dcf75f-986e-45b2-9263-5b52adee1d29@sessionmgr103&vid=0&format=EB&lpid=lp_29&rid=0.

⁷⁵ "Usonian Homeowners and Public Sites Survey," e-mail interview by author, September 2017

Another option for floor installations, which also has applications in ceilings and walls, is a low-profile prefabricated panel system which holds specific sizes of tubing to be placed in between a sub-floor and main floor, or the equivalent in ceilings, etc. This option, however, has implications in the typical Usonian floor.⁷⁶ Unless the existing concrete flooring (or current alternate flooring) is taken up, it would act as the sub-floor and an alternate or additional floor would need to be installed over the pre-fab panels. This could affect the ceiling height of a room or unnecessarily alter or cover up an original existing floor. Other considerations for this include any trim work that would need to be altered, or if no trim work exists, then the flush meeting joints of the flooring and wall. This is a viable option if demolition of the existing floor is necessary to repair the current system, however, the pros and cons of demolition versus the potential considerations of how utilizing a pre-fab panel system could alter the integrity of the home should be taken into consideration.

Chemical or Biological Water Treatment

Chemical and biological water treatment has been an effective means in regulating the chemical changes and corrosive tendencies of the water, as well as organic matter build-up, within a hydronic heating system and may be an advisable option for the maintenance of an existing radiant heat system.

⁷⁶ "SmartTrac Above Floor Subfloor Radiant Heat Panel Solution," Above Floor Subfloor Radiant Heat Panel Solution | Pexheat.com, accessed March 04, 2018, <http://www.pexheat.com/Catalog/SmartTrac>.

In a closed loop system, the water remains relatively static, unless some is lost through leaks or fittings. The water in these closed systems begins as either hard water (raw) or soft water. Every water source has slightly different alkaline levels and chemical make-ups which can affect their corrosive nature. It is true that some hydronic systems will never corrode, however, if the water becomes “soft” it tends to begin corrosive action. The introduction of fresh oxygen through make-up water is another source of change in the chemical content of the water and its’ corrosive tendencies.

Chemically treating the water in a closed loop heating system can eliminate or deter corrosion of existing piping. The first step in determining if water treatment is a viable option for lengthening the life of a radiant heat system is to have the water tested. This can be done by any water treatment or testing company. Once the chemical content of the water is determined then the proper treatment can be concluded. Common types of treatment include Chromates, Sulfites, and Organic Materials.⁷⁷

What Treatment Is Necessary?

All systems and water make-up are different and therefore there is no one best treatment plan. To fully understand the options for water treatment and their benefits and drawbacks a professional should be consulted. The first step in the process is finding a contractor who specializes in water treatment and to ask for a water sample to be tested. Once

⁷⁷ "Chemical Water Treatment," Radiant Professionals Alliance, accessed March 04, 2018, <http://www.radiantprofessionalsalliance.org/Pages/WaterTreatment.aspx>.

the test is complete it would be prudent to consult the water testing facility as well as the contractor about the treatment options.

Boiler Maintenance

Primarily, this discussion has focused on the tubing portion of the radiant heat system. In addition to this, it is also prudent to understand and monitor the boiler, pumps, and valves. It was often mentioned in the survey that yearly maintenance of the boiler was a priority for the owner. These systems do need regular maintenance in the form of cleaning, etc. It is advisable to get on a yearly maintenance plan with a trusted local HVAC company. Additionally, it may be necessary to replace parts or the entire boiler system at some point in its life. If replacement is needed, there are many new high efficiency boilers that should be considered.

Hydronic radiant heating systems can also be powered by different systems, including geothermal, which is what one homeowner switched to in order to heat their home.

Introduction of Air Conditioning or Alternative Heat Source

It is an important for homeowners to understand that this paper is in support of clever and sensitive changes to a home to adapt to modern times and changes in family needs. It is also the author's belief that Frank Lloyd Wright would approve of such modernizations, as he was an architect who consistently used the most current and innovative technologies and would often return to projects to make changes for clients as their families grew or their needs changed.

In this vein of sensitively updating HVAC systems, there are other options for heating a home and introducing air-conditioning for comfort. Many homeowners have done just this. A brief listing of recommendations from other homeowners on these upgrades is included forthwith.

- Ductless Split HVAC Units
- Geo-thermal system
- Dual cooling system: Unesco & Direct Forced
- Air Duct system introduction to roof
- Twin Lennox Pulse Furnace and Associated AC

Ductless Split HVAC units are great options for Usonian homes, as, typically, they do not have existing duct systems. These systems are easy to install and require minimal to no structural changes to the house. A small hole is all that is needed to run conduit that connects the indoor unit with the outside condenser. These systems are also highly efficient as no energy is lost through duct-work.⁷⁸ Also used for cooling and dehumidification, these systems are advantageous for small homes. A downside to this system is the initial cost, which can be one of the most expensive. One homeowner recommended the Daikin brand of ductless air-conditioning units.

Another ductless option for cooling a home, aside from window units, is an Evaporative Cooler, which takes dry outdoor air and cools it using evaporated water. The highlight of this system is its efficiency and its relatively low cost. The caveats included that the system works

⁷⁸"Ductless Mini-Split Air Conditioners," Department of Energy, accessed March 04, 2018, <https://www.energy.gov/energysaver/ductless-mini-split-air-conditioners>

best in an area with low humidity, which may eliminate it as a possibility for many Usonian homes, and requires more regular maintenance.⁷⁹

Geothermal Heat Pumps utilize the relatively constant temperature and natural heat exchange of the ground to heat and cool a home. Closed loop systems have pipes buried in the ground with water running through, providing the regulated temperature. Several factors must be considered before choosing this option including land size, geology, cost, and space. These systems are highly efficient but require some necessary retro-fitting as it typically requires duct-work, which may be a limitation for Usonian homes.⁸⁰

The other three upgrades are variations on forced air duct-based systems. These systems are often expensive to install; however, new models can be highly energy efficient. If considering adding duct-based HVAC into a Usonian home, size, cost, visibility, and energy efficiency should all be considerations.

A Note on Space: Where These Systems Exist and How Best to Retro-Fit?

Usonian homes, while all unique, often have limited space for additional HVAC units in conjunction with the existing. Usually these types of systems, including water heaters and boilers, are in dedicated closets on the ground floor level due to the lack of basements or garages in these designs. Additionally, many homes would not have originally had duct-work in

⁷⁹ "Energy Saver 101 Infographic: Home Cooling," Energy.gov, accessed March 04, 2018, <https://www.energy.gov/articles/energy-saver-101-infographic-home-cooling>

⁸⁰ "Choosing and Installing Geothermal Heat Pumps," Department of Energy, <https://www.energy.gov/energysaver/choosing-and-installing-geothermal-heat-pumps>

place in favor of in-floor heating systems. As one homeowner suggested, duct-work could be added to attics or crawl spaces if these elements are present in the design of the home. The sandwich wall system present in many Usonian homes do not provide for much space to include duct work either. This type of retro-fit may alter the character and integrity of the home. An architect should ideally be consulted when considering implementing these building elements to mitigate any negative impacts to the aesthetic and integrity of the design. If a duct-based system is feasible, the furnace or condenser could be housed in a closet or other existing space in the home. It is important to check on building codes for potentially necessary fire proofing or space requirements for installation of these kinds of systems. Due to these space concerns, the Ductless and Evaporative Cooling systems may be the least intrusive options for cooling and heating in a Usonian home.

Some important questions to ask when considering a new or replacement system:

Is the desired system an AC unit in addition to the existing radiant heat system?

Is there existing duct-work that can be used for an updated system?

A Note on Ventilation

Introducing new systems into a home can have effects on humidity and air quality. Proper ventilation for certain systems are vital not only for air quality but also fire safety. If there is an existing HVAC system in the home, it is likely that there is ventilation. It is important

to discuss if the existing ventilation is adequate for the demands of the new system with the contractors, and, if not, what kind of alterations are needed.

Leaking Roofs

Prevalence of Issue

Wright's preference of designing homes with flat or extremely low pitch roofs created a myriad of issues, with leaks being a major problem. According to survey participants, 84.3% have flat roofs. This does not mean that the entire roofline is flat as many of his Usonian homes feature complex rooflines with multiples pitches and forms. When asked to identify their common preservation issues, 72.2% included leaking roofs. Additionally, roof maintenance, by means of monitoring and removing debris, was consistently listed in the top five maintenance priorities.

Roofs, of course, are one of the elements of a home that do require replacement or major repair during a home's lifetime. Of all respondents, 86.5% indicated that the roof had undergone replacement or major repair during their ownership or stewardship of their Usonian home. As a common issue in these homes, the survey also endeavored to acquire testimonials from homeowners on successful solutions to these roof issues.⁸¹ This will be discussed in greater detail in the next sections.

Understanding Patterns

The chart below further analyzes commonalities of homes whose stewards have identified roof leaks as a major concern. Through a further understanding of the current roofing material, style and pitch of roof, whether or not the roof has undergone major rehabilitations

⁸¹"Usonian Homeowners and Public Sites Survey", email interview by author, September 2017

or replacements, if the steward performs regular maintenance on the roof, and finally identifying if these factors play a role in whether or not leaks are a recurring issue.

An Analysis of Usonian Roof Leaks				
*This Chart Identifies Characteristics of Homes whose Stewards Named Roof Leaks as a Major Concern				
Roofing Material	Style of Roof	Recurring Issue	Regular Maintenance	Major Rehabilitations/Replacement
EPDM	Flat	No	Yes	Yes
EPDM	Flat	Yes	No	Yes
EPDM	Flat	No	Yes	No
EPDM	Flat	Yes	Yes	Yes
EPDM	Flat	No	No	Yes
EPDM	Flat	Yes	Yes	Yes
EPDM	Flat	No	No	Yes
EPDM	Flat	No	No	Yes
EPDM	Flat	No	No	Yes
EPDM	Flat	Yes	Yes	Yes
EPDM	Flat	Yes	No	Yes
EPDM/Acrymax Acrylic Membrane	Flat	No	Yes	Yes
EPDM/Asphalt (shingle)	Flat/Hipped	No	No	Yes
EPDM/Terra-Cotta	Flat/Hipped	Yes	Yes	Yes
EPDM/Terra-Cotta	Flat/Hipped	No	Yes	Yes
Copper/ EPDM	Gable/Flat	No	Yes	Yes
Copper/EPDM	Flat/Hipped	Yes	Yes	Yes
Copper/PVC Membrane	Flat/Hipped/Shed	No	No	No
Copper/Rubber	Flat/Hipped	No	Yes	Yes
Copper/Wood Shingle	Gable	No	No	Yes
Copper	Flat/Hipped	Yes	No	Yes
Copper	Flat/Gable	No	Yes	Yes
Copper/Asphalt (rolled)	Flat	No	Yes	Yes
Copper/Asphalt	Flat/Hipped	No	Yes	Yes
Asphalt (shingle)	Flat/Hipped	Yes	Yes	Yes
Asphalt (rolled)	Flat	No	No	No
Asphalt (rolled)	Flat	No	No	No

Asphalt (rolled)	Flat/Hipped	No	Yes	Yes
Asphalt (rolled)	Flat/Slight Pitch	Yes	No	Yes
Asphalt (rolled) / Asphalt (shingle)	Flat/Gable	No	No	Yes
Asphalt (shingle)	Flat	No	No	Yes
Asphalt	Flat/Hipped	No	Yes	Yes
Wood Shingle	Hipped	No	No	Yes
Wood Shingle/Rubber Membrane	Flat/Shed	No	Yes	Yes
Built Up Ply W/Gravel	Flat	No	No	Yes
Single-Ply Membrane	Flat	No	Yes	Yes
Fiber Tite/Dupont	Flat/Gable	No	Yes	Yes
Tar + Gravel/ Copper	Flat/Gable	No	No	Yes
Modified Bitumen	Flat/Slight Pitch	No	No	Yes
Dex-O-Tex, Built Up Roofing, Slag BUT	Flat	No	Yes	No

EPDM/Flat

The most common combination of material and style of those who identified roof leaks as an issue are flat roofs clad in EPDM. Of the twelve responses with this combination, five identified this as a recurring issue and seven as not. The following data is an understanding of the role that regular maintenance and major rehabilitations and repair play on this roof combination.

57% of the homes with a non-recurring issue had undergone a major rehabilitation of the roof and regular maintenance was not identified as a priority.

29% of the homes with a non-recurring issue had undergone a major rehabilitation and identified regular roof maintenance a priority.

14% of the homes with a non-recurring issue did not undergo a major rehabilitation and only identified regular maintenance as a means of care.

60% of the homes with a recurring issue had undergone a major rehabilitation and identified regular maintenance as a priority.

40% of homes with a recurring issue underwent a major rehabilitation and did not identify regular maintenance as a priority.

0% of homes with a recurring issue identified maintenance as the sole means of care.

With an understanding that the sample set is relatively small and that more factors than those included in this analysis can affect roof leaks, certain patterns can be identified. Homes that have had major rehabilitations or replacements of their roofs are, over all, less likely to have recurring issues. Overall, 33% of respondents indicated that rehabilitation/repair alone has been successful in eliminating roof leaks, however, 42% of homes continue to have roof leaks even with a major rehabilitation or replacement. 50% of respondents had success with either a sole rehabilitation or a combination of regular maintenance and rehabilitation. A very small percentage indicated that maintenance alone was sufficient in solving roof issues.⁸²

⁸² "Usonian Homeowners and Public Sites Survey" email interview by author, September 2017

Copper and Complex Roof Lines

For this analysis' purpose complex roof lines will be identified as any roof with more than one style, or angle of pitch. Homes with copper roofs, except for two, are a part of a complex roof-line with either EPDM or rolled asphalt on the flat section of the roof. Of the ten roofs with copper, only two indicated a recurring roof leak issue. Nine of these homes, an overwhelming majority, have had a major rehabilitaiton or repair to the roof. Six of the respondents indicated that regular roof maintenance was a main priority. Overall, roofs clad in copper in at least one section of the roof, with investments of major repair and regular maintenance, have a relatively low instance of roof leaks.⁸³

Asphalt

Twelve of the homes with leaking roof issues have Asphalt on some section of their roof, or it is entirely clad in this material in either rolled or shingle form. 83% of these roofs do not have recurring leaks, with 70% of those having had major rehabilitations or repairs and 40% indicating regular roof maintenance as a priority. Only 16% have recurring leaks with all of these having major repairs or rehabilitations at some point in their lifetime. Half of these indicate that maintenance is among their top priorities.

Of these asphalt roofs, 50% are a part of a complex roof line and 25% are in conjunction with another roofing material, in these instances either EPDM or Copper.⁸⁴

⁸³ "Usonian Homeowners and Public Sites Survey," e-mail interview by author, September 2017

⁸⁴ Ibid

Conclusions

This chart gives a detailed understanding of the make-up of roofs that have had or continue to have leaks, however, it is also important to consider the roofs that did not indicate leaks as a concern. A total of 49 survey respondents indicated that major rehabilitaitons or repairs had been undertaken on their roofs at some point in time, 13 of these did not indicate that roofs leaks were an issue and therefore are not included in this chart. In total, 38 of the 62 survey respondents indicated that a major rehabilitation/repair alone or a combination of this rehabilitation and regular maintenance has eliminated the issue of leaking roofs.

Roofs with a predominately flat roofline and complex rooflines have nearly identical rates of leak recurrence. Complex roof lines, which are typically roofs with more than one material, are more likely to have undergone major rehabilitations, but only by a 16% margin.

While a promising number, it is still important to understand that building materials degrade over time, and it is common for roofs to need major repair or replacement. Also, regular maintenance is a key tool for identifying issues and solving potential problems before they become serious.

Common Causes of Issue

The most common source of roof leaks is the natural degradation of the roof material over time. Often it is the seams, solders, flashing and other connection areas that are the first to break down and allow water intrusion. It was noted more than once by respondents that a common area of water infiltration is where the chimneys meet the roofline.

Water retention on flat roofs is a common source of leaks in low-slope roofs. This can occur for multiple reasons including, among many potential reasons, negative or poor slope and blocked or inadequate downspouts or scuppers.⁸⁵

Another roof issue mentioned more than once was the built-up roof becoming too heavy and burdensome on the roof truss system. This was also highlighted in the Jacobs' House case study. Years of leaks were responded with installation of another layer of roofing, which may have fixed the immediate problem, but, as mentioned, can cause problems eventually.

If built up roofing is present on a home that is either experiencing sagging or new or continued leaks, a decision must be made if a repair will suffice or if total replacement is necessary. Multiple layers of roofing can create a complex problem, and so if the materials are aging and the roof leak is significant it is most likely necessary to replace the roof. Additionally, replacement will alleviate the extra weight from built-up roofing.

⁸⁵William B. Rose, *Water in Buildings: An Architects Guide to Moisture and Mold* (Hoboken, NJ: John Wiley & Sons, 2005), 102

As stated earlier, it is necessary to replace all roofs at some point in their lifespan. Typically, when these flat roofs are replaced the more common original built-up roofing system was replaced with a more modern and efficient alternative. Those solutions are discussed below.

Understanding Slope, Water Retention, and Ice Damming

Of the survey respondents, 86% indicated that they have flat roofs, 33% gable. Of those, 52% indicated that their homes only feature flat roofs. Complex roofs, with a combination of either flat and hipped or flat and gable totaled at about 37%, with a very clear favor of a combination of flat and hipped. Only 11.5% indicated either hipped or gable as the sole roof style. Understand the slope, angles, how materials are inter-connected, and how water is or is not shed from a roof are important tools in identifying potential problems.

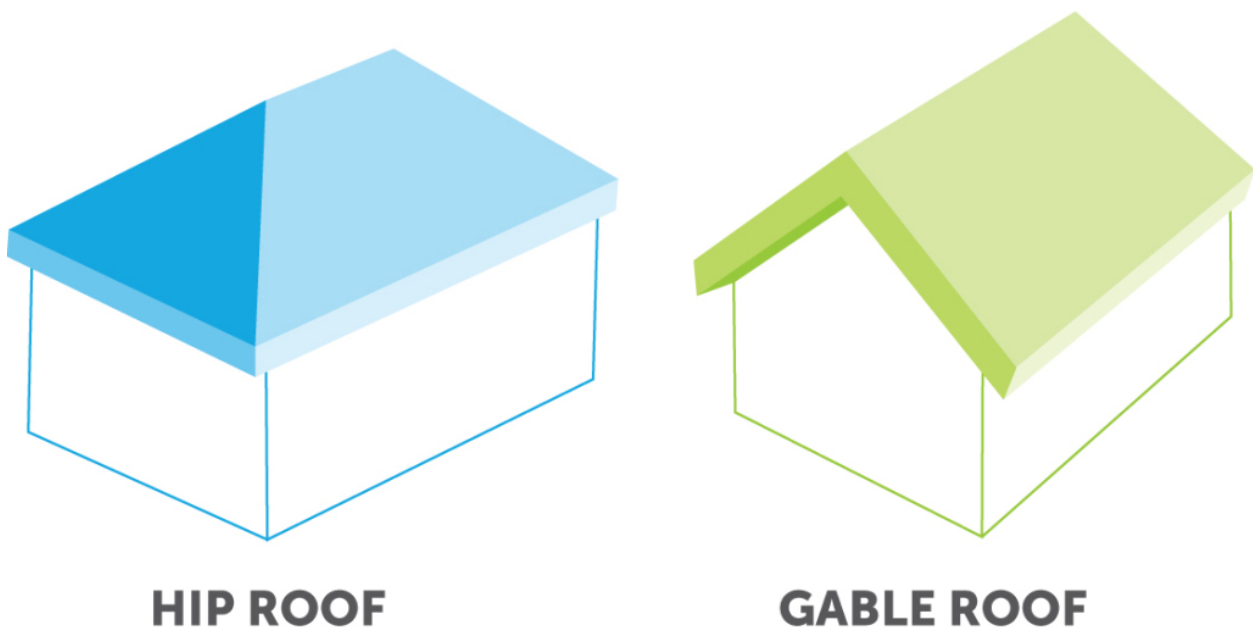

Fig.9 Illustration of Hip and Gable Roof Forms
Source: www.marbex.co.uk

Average rainfall, wind, and the subsequent falling speed and angle of rain all play a role in how well different roof types will hold up based on their ability to shed water. Heavy rains, combined with high winds, can push water into seams or other weak points when these areas normally would not pose an issue.

As the above illustration shows, hip and gable roofs are typically pitched at a percent grade sufficient to shed water and snow from the roof. Flat roofs utilize a low-slope system to push water into downspouts. The junction points of these two, or more, roof slopes in Usonian homes can be particularly susceptible to water intrusion.⁸⁶

On low-slope roofs, which are by far the most common roof form, in at least part, of Usonian homes are susceptible to ponding of water. Typically, flat roofs are actually low-slope roofs that have slight variations in slope to remove water from the roof through downspouts or scuppers (more often seen in conjunction with parapet walls). The volume of water in relation to the slope of the roofs affects how efficiently water can be shed from these types of roofs. Water elimination from low-slope roofs is vital as EPDM, though usually hydrophobic, can in some cases allow water in, which then absorbs into the insulation below, eventually allowing water into the interior. The same theory can be applied to snow load and subsequent thaw, which has the added stress of weight.⁸⁷

Several homeowners indicated that a common roof leak location is where the chimney meets the roofline. It may be true that these areas are creating valleys, or low meeting points, where water collects and funnels as it is being moved. It can often be difficult to flash these

⁸⁶William B. Rose, *Water in Buildings: An Architects Guide to Moisture and Mold* (Hoboken, NJ: John Wiley & Sons, 2005), 98

⁸⁷ Ibid, 102

meeting points properly and can require continual maintenance. All meeting points such as these should be checked regularly, and it may be beneficial to investigate if new or additional flashing is needed.

Ice-damming is another concern in homes in colder climates. Ice damming is the concentration of ice on the eaves of a roof, typically evident by a collection of large icicles. Damming is usually caused by a combination of poor ventilation and heat escaping and warming the eaves of a section of a roof. This heat melts the underside of a snow load, which then can freeze. Additionally, natural water pooling at these edges can have the same effect. Water retention from ice-damming can damage shingles and cause leaks.⁸⁸

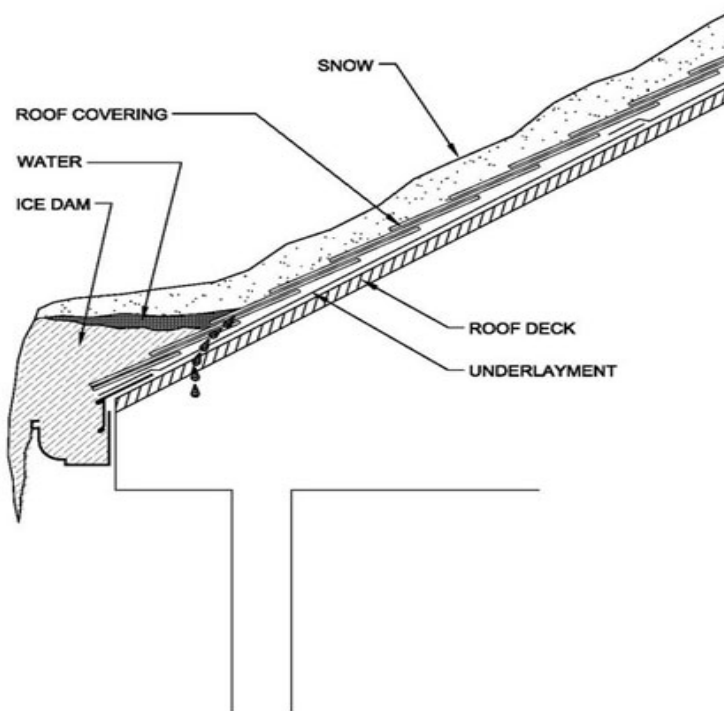

Fig. 10 Graphic of Ice Damming
Source: www.akgeneralroofing.com

⁸⁸ William B. Rose, *Water in Buildings: An Architects Guide to Moisture and Mold* (Hoboken, NJ: John Wiley & Sons, 2005), 114.

Determining the location is the first step in solving an ice-damming problem. If it is near a heat source, like a chimney or stove-pipe then these elements should be checked for heat loss. Insufficient insulation in the attic or blocked vents is another potential cause of ice damming. A qualified roofer should be brought in to assess any serious ice-damming on a home.

Recommended Replacement Material

EPDM Roofing Membrane

EPDM roofing membrane was a common replacement roofing material that was identified by survey takers. EPDM systems are durable, relatively easy to install, and have a long lifespan. There are varying kinds of membranes on the market, however, it is important to consider the amount of space being covered and what grade of membrane is desirable.

One such Ballasted EPDM Roofing System is by Genflex, however, there are multiple companies who make EPDM. This system comes in reinforced or non-reinforced material, in either a 45-mil thickness or a 60-mil thickness. The material and insulation can be laid over many forms of substrate, decking, and insulation. A benefit, and why this type of system is so appealing to Usonian homeowners, is its durability and ability to withstand extreme weather conditions including ice, rain, and ultra-violet light. Additionally, it is resistant to tears and punctures, making it a long-lasting choice for a roof.

With large swaths of roof to cover, a major source of water intrusion are seams. This system counteracts those vulnerabilities with the use of large sections of membrane. Standard widths can range from 10' to 50' and lengths can be up to 200'. This eliminates excessive seams and splices.

The system cannot be applied on a roof slope that exceeds 2"/12" and needs to have a form of ballast on top of the membrane. The ballast should be small and water worn and assists in wicking water off of the roof, protecting the membrane, and continued adhesion to the substrate, and provides uplift resistance from wind.⁸⁹ Ballast will add weight to the system, and a thorough inspection of the roof truss system may be necessary before choosing this type of system. Additionally, this system is relatively inexpensive to install.

TPO

This type of low-slope roofing system has become increasingly popular in the last several years. Thermoplastic Polyolefin (TPO) is a single-ply roofing membrane system that is applied in much the same way and shares many qualities with the formerly discussed EPDM.

While more common for low-slope roofing, it can also be applied on steeper sloped roofs. The large sheets are "heat-welded" at an extreme temperature together to create seams that are stronger than the material itself. The large sheets eliminate the number of seams, making for a more economical installation.

⁸⁹ Gen Flex Roofing Systems , *EPDM Single Ply Roofing Systems* (GenFlex, 2013), , May 2013, <http://genflex.com/wp-content/uploads/2013/05/GenFlex-EPDM-Brochure.pdf>

The membrane is often white or another light color, making this an ideal choice for warmer climates as the membrane reflects UV radiation, keeping the home or building cooler.⁹⁰ This material has the added benefit of being completely recyclable, which, combined with its tendency to reduce emissions from cooling, makes for a highly sustainable product.

PVC

PVC (polyvinyl chloride), a roofing material that is very similar to TPO, has a longer history in the roofing world than the relatively new TPO membranes.

PVC comes in the same basic form as the other single-ply membranes but has the added benefit of being more flexible as compared to TPO and resistant to chemicals like grease or oil. Like PVC, TPO is heat welded and reflects UV light to help regulate internal temperature.⁹¹

Insulation

Insulation is a key part of every roofing system. When thinking about choosing insulation, the thermal performance should be among the top concerns, as well as sustainability, cost effectiveness, and its compatibility with roofing systems.

Polyiso insulation is a type of rigid foam board insulation that is noted for its excellent r-value, fire resistance, low vapor transmission or absorption, and its ability to withstand extreme temperatures.⁹² While there are myriad kinds of insulation, Polyiso is commonly specified as a

⁹⁰ "UltraPly™ TPO," Firestone Building Products Canada, accessed December 11, 2017, <http://firestonebp.ca//roofing/tpo-roofing-systems/ultraply-tpo>

⁹¹ Thomas J Taylor, "PVC vs. TPO: Is the Debate Over?" GAF Blog, June 26, 2017, , accessed December 11, 2017, <http://blog.gaf.com/pvc-vs-tpo-is-the-debate-over/>.

⁹² "Polyiso Insulation," About Polyiso - Polyisocyanurate Insulation Manufacturers Association (PIMA), , accessed December 11, 2017, http://www.polyiso.org/?page=About_Polyiso.

compatible material for the roofing membranes discussed. This option is most ideal if a roof is being replaced, however, there are other kinds of rigid foam board insulation, which are the most ideal form of insulation for low-slope roofs.

There are options for insulation and radiant barrier installation with existing roofs. If any kind of attic access is available, insulation can be installed this way. Radiant barriers are systems which reduce radiant heat gain in a home and are attractive options to reduce cooling costs in warmer climates.⁹³

It is vital to discuss all products with roofing contractors to determine what kind of insulation works best with the chosen roofing system. Minor details, like insulation, sealing materials and methods, and flashing, are equally as important as the main roofing material and can have an impact on any associated product warranties.

Copper Roofs & Flashing

An important part of any roofing system is the flashing. It is common for Usonian homes to have copper roofs and therefore copper flashing is also common. The benefit of a copper roof is the extreme durability as well as the beauty. Metal roofs are a common choice in modern sloped roofing systems, however, copper is no longer a common choice due to cost.

Replacing this type of roofing system can be expensive but can be a character-defining feature of Wright's Usonian homes and an important element to preserve. When dealing with copper roofs and any repair or replacement it is vital to consult an architect or a roofing

⁹³ "Radiant Barriers," Department of Energy, accessed March 12, 2018, <https://www.energy.gov/energysaver/weatherize/insulation/radiant-barriers>

contractor who deals specifically with metal roofing material. Copper flashing extends beyond the copper portions of the roof systems. Flashing is a vital part of a roofing system that can require consistent maintenance.

Maintenance Techniques

Regular roof inspection and maintenance was one of the most common maintenance priorities for Usonian homeowners. Nearly all mentioned some form of roof inspection or cleaning as part of their regular maintenance plan.

Some Wright homes feature gutters and other do not. Typically, on flat roofs, Wright would include downspouts, or something similar, to remove water from the buildings.

Debris collection is something that can become an issue in all homes. It is imperative to clean roofs of leaves and debris on at least a yearly basis. This will alleviate any clogging of drains or gutters which can cause water retention.

While on the roof it would be prudent to inspect all areas and aspects of the roof to keep an eye out for potential problem spots or sources of leaks. If a home has a membrane ballast system, it is important to check the ballast and be sure that it is evenly spread with no bare spots, which could retain and pool water. It is important to note, however, that walking on solder seamed roofs can potentially damage the seams.

Failure of Exterior Wood Finish/Wood Degradation

Prevalence of Issue

It is common that the South and East elevations of these Usonian homes receive a significant amount of weathering and, therefore, are susceptible to failure of the finish material or general degradation and weathering of the woodwork. Even though these elevations are usually exposed to more extreme weather conditions, all exterior wood on all elevations will eventually degrade.

Wright often used wood as an exterior form of siding on these homes. According to the survey, 12.1% of people have redwood siding on a portion of their home, 39.7% have cypress, 24.1% have mahogany, 8.6% have cedar, and 3.4% have douglas fir. In addition to these more common types of wood, respondents also mentioned that they have ponderosa and southern yellow pine on their homes.

With tidewater red cypress being the most common wood type, and mahogany and redwood close behind, this discussion will focus on what is being done to preserve these types of wood. The identification of the wood type is vital to understanding how and why these materials degrade and what is the best way in which to treat them.

The survey also gathered information about the prevalence of the delamination and failure of wood finish material, with this concern often being a precursor to larger and more

serious wood degradation including rot. Of those surveyed, 59.3% responded that wood finish deterioration or failure was a preservation or maintenance issue in their home. This issue tied for second with cracked and damaged flooring for most common issues. Where it should be placed above flooring is in the inclusion of this problem in the listing of recurring issues. Common responses to frequency with which this issue needed to be addressed, in the form of refinishing wood or reapplying finish material, was between 2 to 8 years.

As such a prevalent and ongoing issue, this is something that should be included in all homeowner's regular maintenance plans. Diligent monitoring of vulnerable areas will be key in determining where and when the finish is failing, which is helpful when planning for refinishing or reapplication. A constant attention to this will keep wood refinishing or replacement costs down.

Understanding Materials and Their Properties

Cypress

Tidewater Red Cypress, a particular variety of cypress, is what was most commonly used in Wright's Usonian homes. This wood is found in the swamps of the Gulf South. This wood primarily comes from Louisiana, Georgia, and Florida.

Cypress is claimed to be one of the more durable kinds of wood with an extreme resilience to rot and termite damage. There are examples of the durability of cypress which include the long preserved oldest frame house in St. Augustine. This type of natural rot and pest resilience is indicative of old growth cypress, which was heavily timbered in the early 1900s. By

the 1950s most of the virgin cuts were already made.⁹⁴ Second growth cypress does not have the same rot resilient tendencies as its predecessor and is recommended to be treated with a wood preserver.⁹⁵

The superior structural qualities of cypress include its finer texture, its tendency to uniformly shrink during the drying process, its relatively few defects, and its natural rot and termite resilience. Cypress has a relative moisture content of 5-15% depending on how it was dried and a dry weight of 28 pounds per cubic foot.⁹⁶

It is interesting to note that it was stated by the Southern Cypress Manufacturer's Association that a board and batten system is common and preferable for cypress. When cypress is found in Usonian homes it is most often associated with a board and batten wall system.

Mahogany

Mahogany is most prominently found in the Caribbean, the Central and South Americas, but can be found as far as West Africa. This tree type is broken down into three major species.

Mahogany was harvested and traded heavily in the 18th century and eventually found its way to North America where it was favored for its workability and beautiful coloring and was

⁹⁴ H.L. Williston, F.W. Shropshire, and W.E. Balmer, *Cypress Management: A Forgotten Opportunity*, report, US Department of Agriculture Forest Service, Southeast Area, State and Private Forestry, 1, accessed March 12, 2018, http://ncforestry.info/fs/cypress_management/cypress.pdf.

⁹⁵ H.L. Williston, F.W. Shropshire, and W.E. Balmer, *Cypress Management: A Forgotten Opportunity*, report, US Department of Agriculture Forest Service, Southeast Area, State and Private Forestry, 1, accessed March 12, 2018, http://ncforestry.info/fs/cypress_management/cypress.pdf.

⁹⁶ "Cypress," The Wood Database, accessed December 11, 2017, <http://www.wood-database.com/cypress/>.

popular in furniture making. In addition to furniture, this wood was used in making certain musical instruments due to its tonal qualities.

Mahogany is described as a dense wood with a coloring that can range from a pinkish to a dark reddish. The grain is exceptionally straight in Mahogany, making it easily workable and resistant to warping. Additionally, old growth Mahogany has rot resilient tendencies.

The tree can grow from 150 to 200 ft in height with a 3-6 foot trunk diameter. The average dried weight is 37 pounds per cubic foot. The shrinkage rates are 2.9% radial, 4.3% tangential, and 7.5% volumetric.⁹⁷

These superb qualities made Mahogany a highly coveted and, subsequently, an over harvested wood. Today Mahogany is becoming rare and therefore difficult to procure. Another important note about Mahogany is the sourcing. Both Honduran and Caribbean Mahogany is listed on the Convention on Trade in Endangered Species of Flora and Fauna, which pose restrictions on the trade of these wood species. It is important to understand, if purchasing Mahogany, where it is coming from and the legality of the trade.⁹⁸

Redwood

Redwood is found singularly on the Northwestern Coast of the United States from Northern California to Southern Oregon. The species name is *Sequoia Sempervirens*.

⁹⁷ "Cuban Mahogany," The Wood Database, , accessed November 12, 2017, <http://www.wood-database.com/cuban-mahogany/>.

⁹⁸Rainforestrelief.org, accessed December 11, 2017, http://www.rainforestrelief.org/What_to_Avoid_and_Alternatives/Rainforest_Wood/What_to_Avoid_What_to_Choose/By_Tree_Species/Tropical_Woods/M/Mahogany.html.

One of the largest trees in the world, the Redwood can grow over 300ft tall and has an average trunk diameter of 6-12 feet. The average dried weight of redwood is 26 pounds per cubic foot. The drying shrinkage is 2.4% radial, 4.7% tangential, and 6.9% volumetric.⁹⁹

Common Cause of Issue

No matter which type of wood is included in these homes, it is important to understand what is causing the degradation of the finish material or the wood itself.

Wood is a material that, even with natural rot resilience, is susceptible to weathering and natural aging and deterioration, as are their finishes. The combination of direct UV rays, wind, and precipitation act to degrade the finishes on the wood of these homes. As mentioned before, it is especially prevalent on the south and eastern facades due to increased exposure. One such example of a failed finish material was the varnish that was placed on the southern side of Kentuck Knob.



*Fig. 11 Image of Finish Failure and Soiled Cypress Fascia Board
Source: Image by Author*

⁹⁹"Redwood," The Wood Database, accessed November 12, 2017, <http://www.wood-database.com/redwood/>.

Over time the varnish began to discolor and crack under the sun, and with increased exposure due to this failure, the rain began to beat directly against the fascia and windows causing discoloration.

Once the finish material begins to fail, moisture will find its way into the wood causing a



myriad of issues including discoloration, cracking due to freeze and thaw, and rot. Additionally, when finishes fail the wood becomes more susceptible to insect infestation.

It is vital to understand that finishes are the sacrificial coating and will eventually fail given enough time. As such, the continued monitoring and implementation of consistent maintenance of these coats is vital.

Fig. 12 Cypress Weathering on Southern Elevation
Source: Image by Author

F

Recommended Treatments

Many homes had exterior wood treatments or finishes initially, however, it was also common for Wright to not specify the use of finishes, as he loved the look of natural wood. As such, some homes did not have a finish coat on their exterior woodwork. A wood treatment is typically a coating that is meant to protect the wood from mildew, insects, and UV light. Many wood treatments today serve a dual purpose and are tinted to also act as a finish. Wood finishes vary drastically but are typically a topical product that is used to alter the appearance of the wood in some way.

The following suggestions on treatments come from the results of the survey as tested methodologies for protecting these three main types of wood. All the products recommended below are a combination of peer and professional suggestions. It is important to understand what type of wood is being worked with, what its properties are, the chemical make-up of the finish or treatment material, what its properties are, and how the two will interact. The best way to determine this is to use the product on a test space before applying to the entire surface. Additionally, it may be prudent to consult with a local specialist or contractor on best practices.

Sikkens ProLuxe Cetol RE 1/23

By far the most commonly used recommended product by Usonian homeowners with wood varying from Cypress to Mahogany is a transparent satin finish by PPG, Sikken ProLuxe Cetol RE Wood Finish 1 & 23. In this two-part system are the basecoat and top coat that can be used on many types of exterior wood, including siding and even rough logs.

Cetol 1 is the basecoat which provides a translucent finish that creates the water repellent barrier. Although this product is moisture repellent, an important quality is its ability to allow moisture to escape from the wood as well. A downside to some kinds of varnishes or polyurethane is that it can seal in moisture, causing mildew and salt damage.¹⁰⁰

The top coat, Cetol 23, is what provides the UV protection. This product acts to absorb the UV rays to protect the wood and the coloring. The material can come in a transparent or “natural” color or it can be tinted to match a specific wood type.¹⁰¹

Many homeowners have stated that this is one of the best products to use to protect exterior wood. As with everything, this product will eventually degrade and will need a maintenance coating every few years.

OSMO One Coat Only HS Plus

Another product recommendation is by OSMO, which is a German-based company. They provide a variety of exterior wood finishing products. The one suggested here is the One Coat Only.

¹⁰⁰ Sikkens Proluxe, Proluxe Cetol 1, Cetol 23 Plus, SRD, Log Siding, DEK Finish, , accessed November 12, 2017, http://www.paintsource.net/pages/products/sikkens/sikkens_MAIN.htm.

¹⁰¹ Ibid

This product has the benefit of being a one-step system that boasts many beneficial qualities. OSMO One Coat is a breathable finish that penetrates the wood providing UV protection, water repellency, moisture regulation, and protection against swelling or warping of wood.

This product is untested by the author or known architect and, therefore, a homeowner should consult with a professional and use a test area before covering all wood.¹⁰²

TWP 1500

This stain was suggested by the stewards of the Pope-Leighey house and was used to restore their cypress siding. TWP is much in the vein of the two other products that have been discussed in this paper. This low VOC formula has water repellent features, absorbs UV light, is semi-transparent and aids in retaining the natural coloring of the wood, and assists in protecting against cracking and warping.

This product emphasizes the UV absorbing pigments that assist in prevent wood from graying, which is of special concern with cypress. Thus, this product may be a prudent choice for natural cypress siding to retain its natural coloring.¹⁰³

Cleaning Wood

An important, and sometimes overlooked, aspect to maintaining woodwork is regular and careful cleaning. Wood can become dark over time due to dust, dirt, and mildew build-up. It is vital to use gentle cleaning methods, as harsh chemicals and high pressure or abrasive

¹⁰² "One Coat Only HS," OSMO USA, accessed November 12, 2017, <http://www.ivyhillosmo.com/OneCoat.html>

¹⁰³ "TWP 1500 Series 1 Gallon," TWPStain.com, accessed November 12, 2017, <https://www.twpstain.com/twp-1500-series>

washing can be damaging to wood finishes and bare wood. Often, wood finish products will come with recommendations for cleaning and maintenance. This is the first resource that should be used, if available.

Another consideration for cleaning wood surfaces is the tool that is used. A hard bristle brush can do damage to a wood's finish, just as harsh chemicals can. A soft cloth or soft bristle brush are the first choices when cleaning wood.

When choosing cleaning materials, it is a good choice to use a detergent that is safe for the homeowner, the environment, and for the wood. Simple Green is a cleaning agent that does not include any harsh chemicals. Additionally, Dawn dish detergent with warm water has been used successfully on Kentuck Knob and its cypress siding. It is important to remove any residue of the cleaning agent. The wood should be cleaned or rinsed, finally, with warm water. If warm water will suffice to clean initially, this is the best option. While, these two are among the best options it is important to read ingredients list on all products before use and clean an inconspicuous test section prior to use. Simple Green contains Sodium Citrate, Tetrasodium N, and Sodium Carbonate.¹⁰⁴ These soluble salts could have interactions with nearby masonry and so it is important to be cognoscente of all surrounding materials while cleaning and any potential chemical interactions.

When severe oxidation is present in the wood, it was suggested by one homeowner that a steam generator was successful in removing that discoloration.

¹⁰⁴"Simple Green Product Data Sheets," Simple Green, accessed March 13, 2018, <https://simplegreen.com/data-sheets/>.

Cracked or Damaged Concrete Floors

Prevalence of Issue

Of the sixty-one survey respondents, 93.1% answered that they have concrete floors in their home. The second and third most common floor material was wood and tile at 10.3% and 8.65% respectively.

Concrete flooring was a character defining feature of Usonian homes. As discussed previously, often they would be Cherokee red and have the grid or module system that the home was based on etched into the floor.

As one of the most common features in Usonian homes, it is no surprise that cracked or damaged concrete floors are one of the primary issues in these homes. Of those surveyed, 59.3% selected this as one of their major preservation concerns with their homes. Floor repair or replacement was the fourth most common listed major rehabilitations that occurred during the owner's stewardship.

Common Cause of Issue

Concrete often recalls words like 'indestructible' and 'permanence'. Despite the many strengths of concrete and its uses in large scale construction, it also has inherent weaknesses.

Concrete is made up of an aggregate (usually sand, small stones, or shells), Portland cement (which acts as the binder), and water. The strength and quality of concrete is largely based upon the water to binder ratio.¹⁰⁵

Through the early years of concrete mixing and use, it was discovered that concrete tended to deflect, which severely limited the strength of the concrete. To combat this, metal rods (re-bar) were placed inside the concrete during the pouring process. This is referred to as reinforced concrete. Another form of reinforced concrete utilizes woven metal mesh instead of metal rods, or a combination thereof, to provide the support. Adding in re-bar and mesh increased its tensile strength, and therefore enhanced how this material could be used to build.¹⁰⁶

However, the introduction of metal into the concrete is a source of cracking, delamination, and rust staining in concrete. If the metal inside the concrete comes into contact with any form of moisture it will begin the corrosion process. Rust expands metal, which can cause stress cracks in the concrete. These cracks can then allow more moisture inside. If the concrete is exposed to the weather, freeze and thaw can intensify these issues. Additionally, de-icing salts can be very detrimental to the structural integrity of concrete.¹⁰⁷ For Usonian homes, these issues would primarily come into play in exterior areas.

¹⁰⁵ Paul Gaudette and Deborah Slaton, "Preservation Brief 15: Preservation of Historic Concrete," National Park Service, 2007, 3, <https://www.nps.gov/tps/how-to-preserve/preservedocs/preservation-briefs/15Preserve-Brief-Concrete.pdf>

¹⁰⁶ Robert A. Young, *Historic Preservation Technology* (Hoboken, NJ: J. Wiley & Sons, 2008).116

¹⁰⁷ Paul Gaudette and Deborah Slaton, "Preservation Brief 15: Preservation of Historic Concrete," National Park Service, 2007, 5, <https://www.nps.gov/tps/how-to-preserve/preservedocs/preservation-briefs/15Preserve-Brief-Concrete.pdf>

The issues of corrosion and the subsequent cracks and delamination in concrete is of special concern in Usonian homes where metal pipes are laid inside the concrete slab floor for the hydronic radiant heating system.

These pipes can act in the same way as rebar inside or against concrete flooring. If rust begins, which is very common in these early metal systems, then it can cause rust-jacking and cracking in the concrete flooring.

Concrete floors can also be susceptible to cracks due to expansion and stress even if metal is not a factor. Highly alkali aggregates can react with the silica in the concrete which forms a crystalline gel. This gel will expand if it encounters moisture, causing delamination or stress cracks.¹⁰⁸

Poor construction is another potential cause of scaling, microcracking, delamination, or larger cracks due to the presence of tiny hollow areas within the concrete structure. This can be caused from improper mixing or hand-tamping of the concrete. This is most often seen in pre-WWII concrete. Poor construction can also be an issue when the different pours of concrete are allowed to cure and, therefore, the next pour does not bond properly to the previous layer. This forms what is referred to as a cold joint, allowing water to enter.¹⁰⁹

Another cause of damage to concrete flooring is weather exposure. On exterior concrete surfaces this is caused by snow, ice, rain, and sun exposure. On interior surfaces, this can be caused by pressure washing, abrasive cleaning, or harsh chemicals. Any pressure

¹⁰⁸ Paul Gaudette and Deborah Slaton, "Preservation Brief 15: Preservation of Historic Concrete," National Park Service, 2007,5 ,<https://www.nps.gov/tps/how-to-preserve/preservedocs/preservation-briefs/15Preserve-Brief-Concrete.pdf>

¹⁰⁹ Robert A. Young, *Historic preservation technology* (Hoboken, NJ: J. Wiley & Sons, 2008).123

cleaning with a psi higher than 200 can erode the surface of the concrete and expose the aggregate.¹¹⁰

It is important to note that cracks are extremely common with concrete and not all cracks are signs of failure. However, cracks should be explored to determine causes and addressed to eliminate further issues.

Options for Repair/Replacement

When dealing with concrete, it is important to consider whether repairs will suffice or if replacement is necessary. This is most likely not a decision that can be made without a consultation with a professional. Additionally, if deflection in the concrete in question is noticed, it is imperative to consult a professional.

First, the cause of the problem needs to be determined. Cracks can be fixed; however, more will occur if the underlying cause is not addressed. This is where a condition assessment is conducted. Evidence of efflorescence, or expanded salts left over from moisture in the concrete, is a clear sign of moisture in concrete. In a floor, this can come from the ground through capillary action as concrete is a porous material, or from above via water left on the surface or water intrusion through cracks.

Today, there are many ways to determine the cause of these types of issues. Moisture can be detected through thermal imaging by infrared cameras or by moisture meters. Corrosion

¹¹⁰ Paul Gaudette and Deborah Slaton, "Preservation Brief 15: Preservation of Historic Concrete," National Park Service, 2007,6 , <https://www.nps.gov/tps/how-to-preserve/preservedocs/preservation-briefs/15Preserve-Brief-Concrete.pdf>

can be measured through copper sulfate half-cells.¹¹¹ Typically, these types of analyses need to be performed by professionals.

Once the cause is determined then a course of action can be planned. Cracks that are stationary can be filled with cementitious mortar that can be matched to the existing cement color and texture after petrographic analysis.¹¹² If cracks are not deemed to be stationary, then sealants that will move with the cracks as they expand and contract can be used. These include elastomeric sealants and silicone sealants. If it is necessary to increase the structural integrity of a section of concrete, then an epoxy injection repair can be used. This mixture is injected into small holes in the concrete.¹¹³ The downside to using non-mortar crack repairs, such as elastomeric sealants, is coloring. If the floor does not have paint over the concrete, then this repair may be unsightly.

If cracking is significant or continuous, or if the cause is severe corrosion of metal, then it may be necessary to replace the concrete slab. A qualified contractor should do this. When thinking about replacement in a Usonian home, lines of potential future cracking should be considered. A lesson can be learned from Tarantino Architects and their restoration of the Hanna House. The module system is represented in that house in the form of hexagonal “tiles” in the concrete floor. When the concrete was replaced the lines or joints of the hexagons were deepened with a special trowel to stop cracks from running directly through the hexagons.

¹¹¹Paul Gaudette and Deborah Slaton, "Preservation Brief 15: Preservation of Historic Concrete," National Park Service, 2007, 8, <https://www.nps.gov/tps/how-to-preserve/preservedocs/preservation-briefs/15Preserve-Brief-Concrete.pdf>

¹¹² Paul Gaudette and Deborah Slaton, "Preservation Brief 15: Preservation of Historic Concrete," National Park Service, 2007,13 , <https://www.nps.gov/tps/how-to-preserve/preservedocs/preservation-briefs/15Preserve-Brief-Concrete.pdf>

¹¹³ Ibid

Cracks will follow the weakest path, which is why the deep joints allowed for less damaging pathways for cracks.¹¹⁴

Coloring

Frank Lloyd Wright is well known for his love of the color red. Most Usonian homes were specified by Wright to have Tile Red colored floors using Colorundum, which was produced by AC Horn. In 1938, Wright entered into an agreement with AC Horn to use this system specifically on his Usonian concrete floors. The standard color that was used was Tile Red #1117.

Colorundum was a “shake on” surface hardener that could be tinted to a specific color. This color is not topical but is typically found only in the top “slab” that was common in the Usonian home concrete construction, which sat above the thick base slab. Often, this dual slab system was there due to the heating system construction.¹¹⁵

The equivalent product today is referred to as Lithochrome, however, it is comparable to Colorundum. The color that is the equivalent to Tile Red is Scofield’s A-27 Dark Red.¹¹⁶

These are the ideal products to use when patching or repairing colored concrete flooring to match the existing original. The Scofield color is a liquid pigment. This pigment can be added to mortar mixes to repair cracks. It is important to confer with a specialist to achieve the correct repair and the proper coloring.

¹¹⁴Lawrence Tarantino, "Usonian Colored Concrete Floor Mat," Usonian Essentials, http://www.usonianessentials.com/publications/articles/FLLW_ColorMat%20Oct12.pdf.

¹¹⁵"Interview with Tarantino Architects," telephone interview by author, September 15, 2017.

¹¹⁶ Lawrence Tarantino, "Usonian Colored Concrete Floor Mat," Usonian Essentials, http://www.usonianessentials.com/publications/articles/FLLW_ColorMat%20Oct12.pdf.

Mortar Deterioration

Prevalence of Issue

Of the respondents, 58.6% labeled brick as their primary exterior material and 15.5% labeled stone. With this high percentage of masonry as the exterior material (with roughly the same percentage on the interior), it is reasonable then that 40.7% of survey takers checked off mortar deterioration as a preservation concern in their homes. Actually, it is a wonder that this is not a higher percentage considering that mortar, usually, is the sacrificial material in masonry construction.

Common Cause of Issue

In historic construction methodologies, the mortar layer in masonry construction was typically of a material that was softer and more prone to deterioration as compared to the brick, stone, or cast stone main construction material. This is due to its make-up. Historic mortar is made up of lime, an aggregate, and water. The lime component makes the mortar slightly softer than historic brick and stone. The importance of this comes in the ways in which brick and stone are usually damaged by water.

Efflorescence is a major way in which mortar deteriorates. Salts are ever present in water, which can enter masonry in many ways. A few ways in which water can enter masonry walls is runoff from poor roof drainage, backsplash, and rising damp, which is the process through which water rises from the ground into the masonry via capillary action.

Once water has entered the masonry, it will want to follow its natural cycle and evaporate, finding the easiest path to do so. Accommodating this natural cycle mortar was constructed to be the material through which the water evaporates, leaving behind the salt crystals present in the water. It is the salts left behind that cause the damage to the masonry, as the crystals will expand when the moisture is gone, causing spalling and delamination in masonry walls or mortar joints.

If damage from efflorescence is evident (is visible as white salty residue on the surface of the wall) on the masonry and not the mortar, then there is a chance that the mortar is mixed with Portland cement and is harder and less porous than the masonry material.

In the 1930s and onward, where most of the Usonian homes fall, mortar was made with Portland cement instead of lime or a much higher concentration of Portland vs. lime. The introduction of Portland cement into the mix often made the mortar much less permeable than the stone or brick that was used in the construction.¹¹⁷ This then forced the brick or stone to become the pathway through which water leaves the wall and where the efflorescence damage occurs. In addition to these problems, a too hard mortar for the masonry can cause issues if repair or replacement is necessary of either mortar or masonry. A pneumatic tool or chisel is often needed to remove Portland mortar, which if not done by a skilled professional, can cause damage to the surrounding masonry. In modern building technology, this is less of an issue as bricks are fired at a much higher temperature and often match the hardness and permeability of Portland mortar.

¹¹⁷ "Preservation Brief 2: Repointing Mortar Joints in Historic Masonry Buildings," National Parks Service, accessed November 29, 2017, <https://www.nps.gov/tps/how-to-preserve/briefs/2-repoint-mortar-joints.htm>

Mortar joints are also susceptible to cracking during settling or freeze/thaw cycles as cracks will also find the weakest path to follow. This is another benefit of having a mortar that is softer than the masonry in a building, as mortar is designed to be replaceable.

Options for Repair/Replacement

Most often mortar damage will need to be repointed by a professional mason. The process begins, as always, with understanding the problem and the cause of the problem, then the mortar must be matched for repair or replacement with in-kind make-up, material, texture, permeability, and color. After a suitable match is determined, then the original mortar will need to be removed and the mortar joint cleaned at a depth of two and a half times the width of the joint. Once the joint has been properly cleaned, it will need to be kept moist and the new mortar pointed into the clean joint.

Understanding the Mortar & Replacing In-Kind

It is vital to understand the make-up of the mortar that needs to be repaired or replaced before any work is done. Matching the mortar is important in both repair and replacement projects because different mortar make-ups will not only look different but act differently with the masonry material for the reasons discussed above.

As mentioned, mortar is typically made up of these basic elements: binder (either lime, Portland cement, or a combination of both), aggregate, and water. However, it is not as simple as this. There are several different forms that the lime mix can come in, which all have their own properties. In addition to Portland cement, there is also masonry cement which is used in mortar mixing. The size and make-up of the aggregate is another factor when attempting to

match mortar. This can vastly change the texture and look of a mortar mix. When repairing, it is important to match the color and texture as closely as possible.

In modern mortars, color pigments can be added to assist in matching the color of the original mortar. A professional mason, preservation consultant, or architect can assist with matching the mortar for a repair or replacement project. In addition to simply matching the mortar, a professional mason will also be able to match the pointing style. This is vital to a project as pointing techniques not only look drastically different, but also serve different purposes for different materials.

Hiring a Contractor

With all these things in mind, it is important to be specific when selecting a contractor to perform repointing work. Having this knowledge will assist the Usonian homeowner in asking the right questions when discussing the project with professionals.

Some initial questions may include:

Have you worked on this type of home in the past?

Does your company work with historic buildings?

Can you help me determine the cause of the deterioration?

How will you determine the make-up of the mortar in my home?

Will you match the mortars, color, texture, and permeability?

What are the methods you use to match the mortar in my home?

Will you use an angle grinder or a pneumatic chisel to remove my existing mortar?

If yes, is your staff used to using these tools? I want to make sure that the brick/stone/etc is not damaged in the removal process.

Can you provide references for similar work?

Will you prepare a mock-up for my approval before proceeding with work?

It is important to locate a contractor who has worked on a similar type of home of a similar age and general construction, or a company who specializes in historic masonry. A company that does this will be more likely to be able to match the mortar accurately and take care not to damage the original masonry construction.

Asking these and other questions will help you to choose a contractor who will properly repair or replace the mortar.

Retro-Fitting: Glass

Typically, Usonian homes feature single-pane glass, which leaves homes vulnerable in several ways. The type of glass used was often un-tempered, which if broken can cause life safety issues. Additionally, UV light entering the oftentimes large spans of glazing can cause sun bleaching or fading of many types of materials. The R-value of this type of glass is also a consideration where energy efficiency is concerned.

This section will discuss ways in which existing glass can be retro-fitted to provide protection from the sun, damaging winds, and help to retain heat in the home.

Ultra-Violet Protection

Ultra-violet damage was one of the more common preservation concerns. While this concern was often focused on the exterior wood (this was discussed with exterior wood treatments), it is also important to consider the effects that this can have on the interior. Sun bleaching can occur in many ways including on interior fabrics, woodwork, paintings, etc. Often, the best way to solve this issue is to implement UV protected glass, which comes in several forms.

UV protection was among the least common forms of glass retro-fitting or alterations according to the survey. Only 7% of respondents indicated that they had UV protected glass. Typically, this protection was in conjunction with single pane glass.¹¹⁸

¹¹⁸"Usonian Homeowners and Public Sites Survey," e-mail interview by author, September 2017

Retention of original materials, including glass, is important where possible. However, it is also important, as discussed before, to modernize homes for safety and comfort. UV protective coatings are available which can be adhered directly to existing glass. A few coatings that provide both UV protection and heat gain protection include:

Low Emissivity Coating

- Controls heat transfer, reduce energy costs, control solar gain

Reflective Coating

- Reduce solar radiation

Spectrally Selective Coatings

- Customized for both solar and heat gain¹¹⁹

Thermal Glass

Often with single pane glass, heat retention and r-value are an issue. While often the heating can compensate for the heat loss through the glazing, this may increase energy costs in a home. If this is a concern, then consider replacing the glass with more efficient thermal glass.

Single-pane glass was a common feature in Usonian homes and, according to the survey, 43% of homes have retained solely their single-pane glass. Approximately 36% of homeowners had a combination of single-pane and thermal glass in their homes and 36% only had thermal

¹¹⁹ "Window Types," Department of Energy, accessed November 29, 2017, <https://www.energy.gov/energysaver/window-types>

glass. This data shows an increasing trend toward existing thermal glass in the home or the introduction of thermal glass at some point in the home's life.¹²⁰

Today, the most thermally efficient glass is typically double or triple glazed, with a hermetic seal. The problem with introducing multiple panes of glass is retro-fitting the existing window or door frames. A skilled carpenter could do this if the width of the existing frame is significant enough. If double glazing is not preferable or possible without severely altering the existing frames, there are single glaze options that are more thermally efficient.

¹²⁰"Usonian Homeowners and Public Sites Survey," e-mail interview by author, September 2017

Extraneous Concerns

The preservation issues addressed so far in this paper make-up the most common concerns present in Usonian homes. These, however, do not represent all the issues that were identified in the Homeowner's Survey. The following issues, while equally as relevant as those addressed above, constitute concerns that are highly individual to the site or require immediate attention by a qualified professional and, therefore, are not covered in detail in this paper.

Deflecting/Sagging Cantilevers

Prevalence of Issue

Cantilevered roof structures are often a character defining feature of Wright's designs, and Usonian homes are no exception. From as early as his Prairie Style days in Oak Park, Wright implemented long stretches of "floating" roof lines. Wright's Fallingwater is perhaps the most famous example of this. In total, 23 stewards indicated that sagging or deflecting cantilevered roof sections were a concern in their home. This accounts for 38.8% of all respondents indicating this problem. While not all Usonian homes have these types of roofs, those that do require special attention to these elements if any type of deflection is occurring.

Understanding Construction Methodologies

Cantilevers can be constructed in several different ways for many purposes. In some of Wright's designs, as with Fallingwater, the terraces were cantilevered. In Usonian homes, it is most often the roof structure, commonly the carport, that is built in this manner. Often, as described previously, these extending roof elements are typically created by a truss system

which is commonly a series of 3 2x4s. The roof structure protrudes out over the exterior wall, but is typically supported by either wood or steel beams in these walls. Additionally, these roof truss beams can be counterbalanced either by a masonry core or the rest of the roof, as with Kentuck Knob. In some homes, the support beams were inadequate in the initial construction and either the wood was replaced with steel or additional support beams or fitch plates were implemented.

Identifying and Addressing Deflection

The first step in dealing with any issue is identifying the problem. If original drawing or plans for a home are available, or if the original height between the cantilever and ground is known then measurements can be taken to detect movement. If this is not known, it still may be a good idea to measure these areas at regular intervals. This may be particularly useful after winter, when snow and ice may have put additional weight and stress on the structure.

While this paper has provided some examples of successful solutions this a deflecting cantilever, including the addition of fitch plates or increased beam support in exterior wall, each home will experience variations in construction methodology and issue. Therefore, it is recommended that a qualified professional be brought in to consult on the issue. When dealing with deflection it is vital to consult a professional as soon as possible. A qualified architect or structural engineer would be able to provide more detail about the individual problem and suggest courses of action or means for mitigation.

Textile/Concrete Block Deterioration

Prevalence of Issue

Utilizing data from the survey, 22% of respondents indicated concrete block as an exterior material and 6.8% included textile block. Of those, only a very small percentage indicated having problems with the textile block or concrete block. Despite this relatively minute concern among stewards, it is an interesting and complicated concern which will be discussed in some detail here.

Textile Block Homes

During the early 20th century Wright began building a series of textile-block homes in the Southern California area. Among the most famous include the Ennis House, the Storer House and the Freeman House. The Freeman House underwent a rather extensive rehabilitation for many reasons, but one being the failure of the textile-block system. The system of creating these blocks and the means by which they failed, while not identical to the Usonian model, are representative of this type of construction pathology.

Wright put forward this idea of the textile block in the 1920s and described it, which is also discussed in Jeffrey Chusid's book *Saving Wright* on the matter, in the following way, "the system consists of concrete block slabs about 2-3 inches thick of unit sizes which can be handled, laid on end, with interlocking grooves, reinforced horizontally and vertically by means of steel rods tying the inner and outer shells of the walls. Concrete is poured into the holes

through which the rods extend, forming a complete, weatherproof, structural bond of spidery steel reinforcement between the various units making up the general system of design.”¹²¹

The various molds included a pattern plate and a coffered back. The concrete, typically utilizing local aggregate materials, was poured into the molds and then hammered down to even out the pour. It was then set to cure for approximately three to four weeks in a semi-moist environment.¹²²

The deterioration of these blocks occurs for much the same reasons as discussed previously in the section on concrete flooring and masonry. As steel rods run through the blocks, they are susceptible to rust-jacking and spalling due to water and air intrusion into the block. This was a common cause of deterioration for the Freeman house and other textile-block homes.

A phenomenon more specific to textile-blocks was what author Jeffrey Chusid called a “ring fracture”. When the blocks were pounded with a hammer, small cracks were created along the channels of the blocks, meant to hold them to one another. These small cracks worsen over time as water was allowed to infiltrate, which caused increased spalling and other severe damage.¹²³

In addition to these concerns, the nature of the construction, which was two wythe blocks stacked on top of one another with no mortar between the joints, was also problematic.

¹²¹Jeffrey M. Chusid, *Saving Wright: The Freeman House and the Preservation of Meaning, Materials, and Modernity* (New York: W.W. Norton, 2011), 28.

¹²² *Ibid*, 30

¹²³*Ibid*, 123

This construction methodology in conjunction with the natural stresses of a building and degradation of materials over time serve to cause ever more issues.¹²⁴

Recreating Blocks

While a lesser percentage of Usonian homes feature textile blocks as the major envelope material, these and concrete blocks are far more common in Wright's Usonian Automatic homes, which proposed that people could and should make their own blocks to construct their home.

When a block or set of blocks is deteriorated to a point of needing to be removed, some homeowners have rebuilt their textile or concrete blocks. If the blocks needing replacement are just concrete blocks, then the new blocks can be cast in a much simpler way. However, it is still important to understand how the blocks interconnect within the wall structure. Small nuances can play a large role in the efficacy of recreated blocks working harmoniously with the existing. Unless detailed plans are available, the best way to determine the exact specifications for a new block are to take an existing one from the building and have a mold made from it.

This concept of recreating blocks from molds and the importance of precision are equally as relevant in the textile block system, which often feature patterned coffered blocks.

Molds can be a challenging element to develop as the material and method can alter the size of the ending block. Creating blocks on your own was an innovative way to keep costs down, however, casting concrete is not as simple a process as it appears. It is best to consult a

¹²⁴Jeffrey M. Chusid, *Saving Wright: The Freeman House and the Preservation of Meaning, Materials, and Modernity* (New York: W.W. Norton, 2011), 124.

professional in new blocks need to be created for the home. In addition to the creation of the blocks, the proper deinstallation of the damaged and installation of the new can be a potentially damaging process in itself and should not be undertaken without professional guidance.

Identifying and Addressing Concerns

Cracks

If severe damage of concrete block is evident in a home, then first the cause of damage must be identified. Stresses and movement in foundations can cause cracking of concrete over time and may or may not be a structural concern. If a concerning crack is present, a crack monitoring system should be put in place. These range from the inexpensive do-it-yourself systems to those performed by professionals. The goal of crack monitors is to detect increased movement or stress over a period of time, which can assist in determining severity of the problem.

If cracks are growing at a significant rate then it is best to bring in a structural engineer or architect to determine the cause of the cracks and if they pose a serious structural concern. Often in Wright's designs, the textile blocks were not structural, however, each home will be different. Small cracks which are not growing at a concerning rate can be filled. Crack repair ranges from epoxy fillers to custom mortar mixes. Depending on the location of the crack, it may be the best option to fill the crack with a mortar that closely resembles that of the original material. This can be determined in the same manner as the previous discussion on mortar, with a professional analysis of the aggregate and binder make-up.

Biogrowth

Biogrowth is another common problem with concrete block and other masonry materials. Biogrowth comes in many forms, from small black lichen that appears almost like dirt to small plants or moss growing from cracks in the masonry. Biogrowth is typically a product of water, whether it be on the surface of the concrete block or within. This type of problem is typical and can be cleaned with a product such as D2 Biological Solution. This product is highly efficient at removing organic material from masonry, however, it works best on small growth. It is also important to note that sometimes the growth, while dying can turn an orange color. It is prudent to test this product on a small area before cleaning the total affected area.

Waterproofing

Some Usonian homeowners and stewards expressed concerns about water proofing their concrete block or identified this as a top maintenance priority. In *Saving Wright*, Chusid mentions that Wright specified the use of a waterproofing material on the Freeman House, which was never implemented.¹²⁵ Concrete is, at least slightly, a porous material and allows water to enter at a certain rate. The make-up of the masonry determines the rate at which water infiltrates the material. To prevent water from seeping into the concrete from rain and backsplash, waterproofing coatings, which are often silicone based, can be applied to a concrete surface to decrease the ability of water to absorb into the wall. These treatments can be somewhat effective under some circumstances; however, it is important to understand that

¹²⁵ Jeffrey M. Chusid, *Saving Wright: The Freeman House and the Preservation of Meaning, Materials, and Modernity* (New York: W.W. Norton, 2011), 184.

if water is entering into the concrete block from a location other than where the waterproof coating is applied, it could cause more harm than good.

Rising damp, which is water wicking up into masonry walls through capillary action, is a problem for many homes. If water enters a masonry wall construction in this manner with a waterproof coating, it becomes trapped, which can cause a significant amount of damage via subfluorescence, freeze and thaw cycles, biogrowth, and general deterioration. It is vital that water vapor is allowed to evaporate out of a masonry material; it essentially needs to be able to breathe. Damp courses, today usually a metal or plastic material, can be implemented in between concrete block courses to stop the flow of water up and through the wall and are an option that should be explored if this is determined to be an issue. To mitigate these kinds of potential problems, it is important to understand where the water is entering the concrete block.

When thinking about applying a “water-proof” coating to the exterior of a home it is important to consider the possible effects. Many elastomeric masonry coatings are effective in keeping water out of a home, however, if water does find its way in it becomes trapped. Therefore, a water repellent coating, which does not create a vapor barrier, is a more favorable choice to protect concrete block and textile block from water.

Resources for Locating Specialized Contractors & Materials

Locating specialized contractors/craftsmen and materials for preservation projects were among the two most common maintenance or preservation concerns in Usonian homes. Of the respondents, 41% stated that locating original materials was a concern and 48% included finding specialized contractors and craftsmen.

It can be argued that these two are among the most important elements of any restoration project in a Usonian home. Original materials are vital for the true understanding, aesthetic, and character-defining features of any Usonian home. These materials can be anything from hardware to wood to mortar.

For these projects to be carried out it is best, when possible, to hire contractors or other building professionals who have experience in working on Usonian homes or other Frank Lloyd Wright buildings. If these professionals are not available, then contractors or specialists with experience working with historic homes or who specialize in specific areas of need should be found where possible.

Due to the vast differences in location, need, and the constant changing nature of resources it is not feasible for this paper to provide adequate references. The Frank Lloyd Wright Building Conservancy provides a resource list on their website, which should serve as the first point of reference when searching for contractor, architects, materials, and the like. Other potential resources include local universities, the Frank Lloyd Wright Foundation, and professional preservation organizations or firms.

Conclusions

Beginning Questions and Evolving Goals

This research project was undertaken to answer a series of questions. The author's own experiences and a desire about brought the initial questions to understand if patterns were present in the conservation issues in Usonian homes. The initial questions include the following:

Do all Usonian homes experience similar material failures?

Are there patterns present in the ways Usonian homes are built and why they deteriorate?

What are other stewards and homeowners doing to deal with these issues?

Are there lessons to be learned from the successes and failures of other homeowner's preservation projects?

The survey was the main forum for answering these questions. While there was an expectation of what the results of the survey would be, the results proved to drive the recommendations that were eventually included in this paper.

The goals of this paper changed over time. Initially, it was the goal to address every concern that was presented in the survey. However, the limitations and usefulness of a resource like this was realized and helped to create a more focused understanding of the achievable goals of this paper. First, it was quickly realized that even though there are patterns in the preservation concerns in these types of homes there is a great variety in style, material, landscape, and conservation history which prompts unique concerns that require unique solutions.

With this uniqueness in mind, the goal of this paper was focused on identifying existing patterns in common concerns and providing a base understanding of these issues. Each major concern is broken down into an understanding of the prevalence of the issue, how these materials or elements break down, identifying commonalities or recommendations in ways of dealing with these issues, and presenting options for mitigation of these concerns. All the suggestions in this paper are the result of interviews with professionals and stewards who have direct experience with Usonian homes, the suggestions and experiences shared by the respondents of the Usonian Homeowner's Survey, and additional research of products, methodologies, and general accepted conservation and building pathologies.

The end goal, as expressed initially, was always to provide a resource for Usonian Homeowners and Stewards to assist them in making informed decisions when addressing preservation concerns. Peer based recommendations combined with additional research-based knowledge create an easily accessible and understandable resource for those currently taking care of these home and any future stewards. This resource is meant to be a starting point in understanding patterns of failure in Usonian homes and thinking about ways to deal with these concerns in a mindful way.

Identifying Patterns, Providing Recommendations, and Realizing Limitations

The results of the survey identifying the most common preservation concerns in Usonian homes was largely expected. However, the in-depth sharing of experiences provided invaluable knowledge in identifying patterns both in degradation and mitigation. This sharing of knowledge provides the basis for the recommendations in this paper and, hopefully, will

provide current and future homeowners and stewards with the necessary resources to make educated preservation-minded decisions about their Usonian homes.

The major concerns that were addressed in-depth in this paper, including wood finish degradation, concrete floor failure, radiant heat failure, roof leaks, and mortar deterioration, among others, were chosen because of the ability to identify patterns of failure, apply general preservation pathologies, and the ability of these pathologies to be applied to a large majority of Usonian homes.

The other addressed concerns, including landscaping and cantilever failure, were identified as limitations of this paper. While these concerns were identified as common issues in the survey, it was realized that the either structural or extremely individualized nature of these concerns prevented this paper from being able to provide as much detail, history, or recommendations as compared to other concerns.

Hope for the Future

Frank Lloyd Wright's Usonian homes are a unique example of residential architecture by one of America's most treasured architects. They provide an early example of moderate cost housing that exemplifies Wright's views on organic architecture; a concept that deeply resonates in today's philosophies on housing, the way we experience architecture, and developing a sustainable future. Not only is it important to preserve Usonian homes as examples of past architecture, it is also important to preserve them as inspiration for future building.

By developing this resource and bringing together the thoughts and goals of those most invested in preserving these homes, a conversation can be fostered and continued surrounding ways in which these homes can be properly cared for and kept for future generations. It is the hope that this paper, in conjunction with the work of the Frank Lloyd Wright Building Conservancy and other organizations focused on continuing Frank Lloyd Wright's legacy, will provide useful resources for Usonian homeowners, stewards, and anyone interested in preserving or learning more about these homes and inspire all to want to protect these important pieces of architecture. Moreover, it is the hope that this paper will be a catalyst for future research and better understanding of these as well as an inspiration for those working with Usonian homes to think about best practices for protecting and preserving them.

Works Cited

- "A Look at Radiant Heating Systems." Old House Online. July 2010.
<https://www.oldhouseonline.com/articles/a-look-at-radiant-heating-systems>.
- "Bachman Wilson House." Frank Lloyd Wright - Bachman Wilson House | Tarantino Architect. Accessed November 12, 2017. <http://www.tarantinostudio.com/pres/bachwilson.html>.
- Broach, Barbara Kimberlin., Donald E. Lambert, and Milton Bagby. *Frank Lloyd Wrights Rosenbaum House: the birth and rebirth of an American treasure*. San Francisco: Pomegranate, 2006.
- Butler, Emily. *Kentuck Knob Archive*. Preservation Records - Unpublished, Chalk Hill . Series of unpublished private documents created by the author for Kentuck Knob
- "Chemical Water Treatment." Radiant Professionals Alliance. Accessed March 04, 2018.
<http://www.radiantprofessionalsalliance.org/Pages/WaterTreatment.aspx>.
- "Choosing and Installing Geothermal Heat Pumps." Department of Energy.
<https://www.energy.gov/energysaver/choosing-and-installing-geothermal-heat-pumps>.
- Chusid, Jeffrey M. *Saving Wright: the Freeman House and the Preservation of Meaning, Materials, and Modernity*. New York: W.W. Norton, 2011.
- "Cuban Mahogany." The Wood Database. Accessed November 12, 2017. <http://www.wood-database.com/cuban-mahogany/>.
- "Cypress." The Wood Database. Accessed December 11, 2017. <http://www.wood-database.com/cypress/>.
- DeStefano, Jim, P.E. *From Experience: Fitch Plate Beams* . PDF. Structure Magazine, June 2007.
- "Ductless Mini-Split Air Conditioners." Department of Energy. Accessed March 04, 2018.
<https://www.energy.gov/energysaver/ductless-mini-split-air-conditioners>.
- "Energy Saver 101 Infographic: Home Cooling." Energy.gov. Accessed March 04, 2018.
<https://www.energy.gov/articles/energy-saver-101-infographic-home-cooling>.

Enrich, Doreen. *Usonian Houses: Frank Lloyd Wright at a Glance*. London, UK: PRC Publishing, 2002.

Gen Flex Roofing Systems. *EPDM Single Ply Roofing Systems*. GenFlex, 2013. May 2013.
<http://genflex.com/wp-content/uploads/2013/05/GenFlex-EPDM-Brochure.pdf>.

"FDR's Alphabet Soup." Ushistory.org. Accessed November 13, 2017.
<http://www.ushistory.org/us/49e.asp>.

Gaudette, Paul, and Deborah Slaton. "Preservation Brief 15: Preservation of Historic Concrete." National Park Service. 2007. <https://www.nps.gov/tps/how-to-preserve/preservedocs/preservation-briefs/15Preserve-Brief-Concrete.pdf>.

Hagan, Bernardine, and Frank Lloyd Wright. *Kentuck Knob: Frank Lloyd Wrights house for I.N. and Bernardine Hagan*. Pittsburgh, PA: Local History Co, 2005.

"Historical Importance." Frank Lloyd Wright - The Jacobs House - Usonia I. Accessed November 12, 2017. http://www.usonia1.com/11_read_02.html.

Martinelli, Bill . "Jacobs House I Interview." Telephone interview by author. September 18, 2017.

"One Coat Only HS." OSMO USA . Accessed November 12, 2017.
<http://www.ivyhilllosmo.com/OneCoat.html>.

Pfeiffer, Bruce Brooks., and David Larkin. *Frank Lloyd Wright: master builder*. London: Thames & Hudson, 1997.

Pimlott, Mark. "Frank Lloyd Wright & Broadacre City (2007)." Art Design Cafe. Accessed November 12, 2017. <https://www.artdesigncafe.com/Frank-Lloyd-Wright-2007-1>.

"Polyiso Insulation." About Polyiso - Polyisocyanurate Insulation Manufacturers Association (PIMA). Accessed December 11, 2017. http://www.polyiso.org/?page=About_Polyiso.

"PPG ProLuxe Transparent Satin Cetol 1 RE." March 2017. Accessed November 12, 2017.
https://buyat.ppg.com/REP_PafPaintTools_files/Sikkens%20US/tdb/SIK410.pdf.

"PPG ProLuxe Transparent Satin Cetol 23 Plus RE." March 2017. Accessed November 12, 2017. https://buyat.ppg.com/REP_PafPaintTools_files/Sikkens%20US/tdb/SIK430XX.pdf.

"Preservation Brief 2: Repointing Mortar Joints in Historic Masonry Buildings." National Parks Service. Accessed November 29, 2017. <https://www.nps.gov/tps/how-to-preserve/briefs/2-repoint-mortar-joints.htm>.

"Radiant Barriers." Department of Energy. Accessed March 12, 2018. <https://www.energy.gov/energysaver/weatherize/insulation/radiant-barriers>.

"Radiant Heating." Department of Energy. Accessed November 12, 2017. <https://www.energy.gov/energysaver/radiant-heating>.

"Radiant Heating Systems - Floors." Penn State University . Accessed November 12, 2017. <https://www.e-education.psu.edu/egee102/node/2111>.

Rainforestrelief.org. Accessed December 11, 2017. http://www.rainforestrelief.org/What_to_Avoid_and_Alternatives/Rainforest_Wood/What_to_Avoid_What_to_Choose/By_Tree_Species/Tropical_Woods/M/Mahogany.html.

"Redwood." The Wood Database. Accessed November 12, 2017. <http://www.wood-database.com/redwood/>.

Reisley, Roland, and John Timpane. *Usonia, New York: building a community with Frank Lloyd Wright*. New York: Princeton architectural publications, 2001.

"Restoration." Frank Lloyd Wright - The Jacobs House - Usonia I. Accessed November 12, 2017. http://www.usonia1.com/03_rest.html.

Rose, William B. *Water in Buildings: An Architects Guide to Moisture and Mold*. Hoboken, NJ: John Wiley & Sons, 2005.

Ruff, Joshua. "Levittown: The Archetype for Suburban Development." HistoryNet. June 22, 2016. Accessed November 12, 2017. <http://www.historynet.com/levittown-the-archetype-for-suburban-development.htm>.

Sergeant, John. *Frank Lloyd Wright's Usonian Homes: Designs for Moderate Cost One Family Homes*. New York , NY: Whitney Library of Design , 1976.

Sikkens Proluxe, Proluxe Cetol 1, Cetol 23 Plus, SRD, Log Siding, DEK Finish. Accessed November 12, 2017. http://www.paintsource.net/pages/products/sikkens/sikkens_MAIN.htm.

"Simple Green Product Data Sheets." Simple Green. Accessed March 13, 2018. <https://simplegreen.com/data-sheets/>.

"SmartTrac Above Floor Subfloor Radiant Heat Panel Solution." Above Floor Subfloor Radiant Heat Panel Solution | Pexheat.com. Accessed March 04, 2018. <http://www.pexheat.com/Catalog/SmartTrac>.

Tarantino, Lawrence. "Usonian Colored Concrete Floor Mat." Usonian Essentials . http://www.usonianessentials.com/publications/articles/FLLW_ColorMat%20Oct12.pdf.

"Interview with Tarantino Architects." Telephone interview by author. September 15, 2017 .

Taylor, Thomas, PhD. "PVC vs. TPO: Is the Debate Over?" GAF Blog. June 26, 2017. Accessed December 11, 2017. <http://blog.gaf.com/pvc-vs-tpo-is-the-debate-over/>.

"TWP 1500 Series 1 Gallon." TWPStain.com. Accessed November 12, 2017. <https://www.twpstain.com/twp-1500-series>.

"UltraPly™ TPO." Firestone Building Products Canada. Accessed December 11, 2017. <http://firestonebp.ca//roofing/tpo-roofing-systems/ultraply-tpo/>.

"Usonian Homeowners and Public Sites Survey." E-mail interview by author. September 2017.

Volner, Ian, and Michael Kirkham. *This is Frank Lloyd Wright*. London: Laurence King Publishing, 2016.

Walser, Lauren. "Pope-Leighey House Prepares for Frank Lloyd Wright's 150th Birthday ." SavingPlaces. Accessed November 13, 2017. <https://savingplaces.org/stories/pope-leighey-house-prepares-for-frank-lloyd-wrights-150th-birthday>.

Williston, H.L, F.W. Shropshire, and W.E. Balmer. *Cypress Management: A Forgotten Opportunity*. Report. US Department of Agriculture Forest Service, Southeast Area, State and Private

Forestry. Accessed March 12, 2018.
http://ncforestry.info/fs/cypress_management/cypress.pdf.

"Window Types." Department of Energy. Accessed November 29, 2017.
<https://www.energy.gov/energysaver/window-types>.

"Woodlawn & Pope Leighey." Woodlawn & Frank Lloyd Wrights Pope-Leighey House. Accessed November 12, 2017. <http://www.woodlawnpopeleighey.org/aboutwoodlawn/>.

Woodson, Roger Dodge. *Radiant Floor Heating*. New York: McGraw-Hill, 2010. Accessed November 12, 2017.
http://web.b.ebscohost.com.libproxy.tulane.edu:2048/ehost/ebookviewer/ebook/bmxlYmtfXzl5MTQ1M19fQU41?sid=36dcf75f-986e-45b2-9263-5b52adee1d29@sessionmgr103&vid=0&format=EB&lpid=lp_29&rid=0.

Wright, Frank Lloyd, and Andrew Saint. *An Organic Architecture the Architecture of Democracy*. London: Lund Humphries, 2017.

Www.pexuniverse.com, PexUniverse. "PEX Tubing Technical Specifications and General Installation Recommendations." PEX tubing technical specifications and general installation practices. Accessed November 12, 2017. <https://www.pexuniverse.com/pex-tubing-technical-specs>.

Young, Robert A. *Historic Preservation Technology*. Hoboken, NJ: J. Wiley & Sons, 2008.

Image Citations

Cypress Weathering on Southern Elevation, Chalk Hill, Pennsylvania. Personal photograph by author. August 2017.

Ice Damming Illustration. Digital image. AK General Roofing . Accessed March 21, 2018.
<http://www.akgeneralroofing.com/ice-dams>.

Illustration of Hip and Gable Roof Forms. Digital image. Marbex Limited . Accessed March 21, 2018.
<https://www.marbex.co.uk/carpentry-contracting/cut-pitch/gabled-roof/>.

Image of Broadacre City Model. Digital image. Metropolis Magazine. July 2, 2014.
<http://www.metropolismag.com/cities/what-broadacre-city-can-teach-us/>.

Image of Finish Failure and Soiled Cypress Fascia Board, Chalk Hill, Pennsylvania. Personal photograph by author. August 2017.

Kentuck Knob Carport Roof. Digital image. Kentuck Knob. Accessed March 27, 2018.
<http://kentuckknob.com/preservation-series-car-port-roof/>.

Koshhollek, Joe. *Image of Herbert Jacobs House*. Wisconsin.

Rosenbaum House Interior. Digital image. Wright in Alabama. Accessed March 27, 2018.
<http://wrightinalabama.com/?p=409>.

Street View of Rosenbaum House. Digital image. Wright in Alabama. Accessed March 27, 2018.
<http://wrightinalabama.com/?p=409>.

View of Southern Terrace at Kentuck Knob. Digital image. Kentuck Knob. Accessed March 27, 2018.
<http://kentuckknob.com/>.

Wright, Frank Lloyd. "Plan - Alterations for Mr. & Mrs. Paul R. Hanna (No. 149 with Building Dept. submitted stamp.)" Digital image. Stanford Libraries: Hanna House Collection. Accessed March 14, 2018. Plan - alterations for Mr. & Mrs. Paul R. Hanna (No. 149 with Building Dept. submitted stamp.).

Wright, Frank Lloyd, "Plan, Sturges House," *Digital Collections - University at Buffalo Libraries*, accessed March 13, 2018, <https://digital.lib.buffalo.edu/items/show/30753>.

Appendix

Appendix A.

Homeowners and Public Sites Survey Questionnaire

Frank Lloyd Wright Homeowners Survey

Dear Frank Lloyd Wright Homeowner and Steward,

In coordination with the Frank Lloyd Wright Building Conservancy, I am sending you a survey about your Frank Lloyd Wright designed Usonian home. We hope that the information gathered in this survey will further the Conservancy's and my goal of helping to preserve the work of Frank Lloyd Wright by giving new insight into common preservation issues that you, the stewards of these Usonian masterpieces, encounter.

As a fellow steward of a Wright Usonian home (Kentuck Knob in Chalk Hill, PA) and a candidate for a Master's Degree in Historic Preservation at Tulane University, I am focusing my thesis on the preservation of Wright's Usonian residential designs. This survey is the first step in my research for my thesis, which has as its goal a compilation of common preservation issues and concerns in Wright's Usonian homes across the United States.

With this information, and related research I am conducting I hope to develop a comprehensive preservation resource for Wright homeowners and stewards. This information will be available to homeowners through my thesis on file in the library at Tulane University as well as through data shared with the Conservancy.

Please be assured that no identifiers, such as names of owners or names and addresses of homes will be included in my thesis.

Please complete the survey by October 30th.

Thank you so very much for assisting me in creating something that I believe in and feel will contribute to the knowledge on preserving Wright's residential architecture.

If you have any questions or concerns or would like to contact me directly I would be happy to further explain my research plan.

Best,

Emily Butler
Head of Preservation - Frank Lloyd Wright's House on Kentuck Knob
Tulane University Masters of Preservation Studies Candidate
ebutler4@tulane.edu / ebutler@kentuckknob.com
412-418-3140

General

This section serves to gather general information regarding your home

1. Your Name

2. Are you a current or former owner/steward of a Frank Lloyd Wright home?

Mark only one oval.

Current

Former

3. How many years have you, or did you, own or steward this Frank Lloyd Wright home?

4. Historic Name of Home (Name of Original Client)

5. City and State of Home

6. Current Square Footage (if known)

7. If your house has been added onto from the original Wright design, what is the square footage of the addition if known?

Structural

This section aims to gather information about the physical components of your home

8. Building Exterior Material (check all that apply)

Check all that apply.

- Concrete Block
- Stucco
- Stone
- Brick
- Wood (species not known)
- Redwood
- Cypress
- Cedar
- Mahogany
- Oak
- Textile Block
- Other: _____

9. Building Interior Materials (check all that apply)*Check all that apply.*

- Concrete Block
- Stone
- Plaster
- Drywall
- Wood (species not known)
- Redwood
- Cypress
- Cedar
- Mahogany
- Oak
- Textile Block
- Brick
- Other: _____

10. Current Roofing Material (check all that apply)*Check all that apply.*

- Copper
- Slate
- Wood Shingle
- EPDM /Rubber Membrane
- Asphalt (rolled)
- Asphalt (shingle)
- Terra Cotta
- Other: _____

11. Roof Form (check all that apply)*Check all that apply.*

- Flat
- Hipped
- Gable
- Other: _____

12. Current Flooring (check all that apply)*Check all that apply.*

- Stone
- Concrete
- Linoleum
- Wood
- Tile
- Other: _____

13. Current Window Type (check all that apply)*Check all that apply.*

- Casement
- Single/Double Hung Sash
- Hopper
- Clerestory
- Skylight
- Fixed
- Other: _____

14. Window Material (check all that apply)*Check all that apply.*

- Wood
- Metal
- Single pane glass
- Thermal glass
- UV Protected Glass
- Leaded Glass
- Other: _____

15. Heating System*Check all that apply.*

- In-Floor Radiant
- Forced Air
- Radiator
- Other: _____

16. Electrical Systems*Check all that apply.*

- Original
- Replaced
- Both
- Other: _____

Maintenance

This section is critical for my analysis of Wright's Usonian homes and their associated preservation issues. As maintenance is key for all homes, this section is gathering information on what you as the homeowner consistently do to maintain your home. Some of the items in the common preservation issues question may be one-time fixes. If they are, leave them out of this section. Those items can be discussed in the section "Rehabilitation and Renovation."

17. What general condition was the house in when you took ownership?*Mark only one oval.*

- Excellent
- Good
- Fair
- Poor

18. Below is a list of common preservation or maintenance issues for Usonian homes. Please check off as many as apply to your home.*Check all that apply.*

- Radiant Heating System Failure
- Cracked/Damaged Floors
- Wood Treatment (varnish/clear coating) Failure
- Door and Window Hardware Stripping or Failure
- Window/Door Failure
- Sagging Cantilever
- Roof Leaks
- Stone Cracking in Fireplaces
- Retaining Walls
- Sun Bleaching of Wood
- Locating Original Materials for Restoration Projects
- Locating Specialist Contractors/Craftsmen
- Water Damage Via Skylight/Trellis Openings
- Mortar Deterioration
- Other: _____

19. Are any of these issues recurring? If yes, please list which.

20. How often do you need to address these issues?

Check all that apply.

- Once a year
- Every two years
- Every 5 years
- Every 10 + years
- Other: _____

21. If you would like, please elaborate on any personal experiences with these issues.

22. If you have any specific products or methods that have been successful for you in your preservation projects, please briefly describe them here.

23. Briefly describe your top 5 regular maintenance priorities for preserving your home.

Rehabilitation & Renovation

This section aims to gather information about major renovations or replacements of materials or building systems. This includes issues that have been solved by one-time renovations and are not a part of your regular maintenance.

24. Has the home undergone major renovations on or replacements of the following systems during your ownership? Check all that apply.

Check all that apply.

- Roof Renovations/Replacement (if yes, see below)
- HVAC (if yes, see below)
- Floor (if yes, see below)
- Masonry (Repointing or Replacement of Material)
- Window Replacement
- Door Replacement
- I don't know
- Other: _____

25. Roof, HVAC, and Floor issues are common in Usonian homes. We would be interested to know as much specific information about this as you are willing or able to give.

26. If you know of any major renovations or replacement of material or building systems prior to your ownership, please briefly describe below.

27. When dealing with these issues, what are your primary preservation resources? Please check all that apply.

Check all that apply.

- Architect
- Engineer
- Historic Preservation Consultant
- Conservator
- Local Contractor or Craftsman
- Frank Lloyd Wright Building Conservancy
- Frank Lloyd Wright Foundation
- Association for Preservation Technology
- National Center for Preservation Technology and Training
- Local or University Library
- Google
- Other: _____

28. **Please feel free to add any other information, including referrals for restoration professionals and trades people, you would like to share about this home and your preservation projects below!**

Preservation Education

The ultimate goal of this thesis is to protect as many Usonian homes as possible, by providing practical preservation information and education for Usonian homeowners. This section serves to inquire as to how owners would like to receive this information.

29. **Would you be interested in practical information that is focused on homeowner maintenance issues?**

Mark only one oval.

- Yes
- No

30. **In what form would you like this information?**

Check all that apply.

- Internet Articles
- FLWBC Newsletter
- FLWBC Conference Seminars
- Webinars
- Online Videos
- Other: _____

Continued Protection

31. **There are many ways in which a home can be protected or recognized as a significant historical resource. Please check off if any of these designations applies to your home.**

Check all that apply.

- Individual Local Landmark
- Local Landmark District
- Individual National Register Listing
- National Register District
- Preservation Easement

32. A preservation easement acts as a permanent protection for the historical integrity of your home. Would you be interested in donating a preservation easement on your home? If so, the Conservancy will forward information directly to you.

Mark only one oval.

- Yes
- No
- Already Under Easement
- Other: _____

33. Please feel free to add any other information you would like to share about your home or your preservation projects below!

Thank You!

Thank you very much for taking the time to fill out this survey.

I sincerely hope that this project will be of use to you and act as a future resource for decision making on preservation issues in your home.

A wonderful part of owning or managing a Wright home is the community that comes with it, and your involvement with this project will not only help me in my academic endeavor, but contribute to the larger Frank Lloyd Wright community.

With heartfelt gratitude,

Emily

